

W22

Three-Phase Electric Motor High Efficiency E3

Technical Catalogue
AUSTRALIA / NEW ZEALAND

- High efficiency E3
- High torque
- IP66, class H
- WISE® insulation
- Low noise level
- Superior lifetime
- Lower maintenance

W22 Industrial



W22 Mining

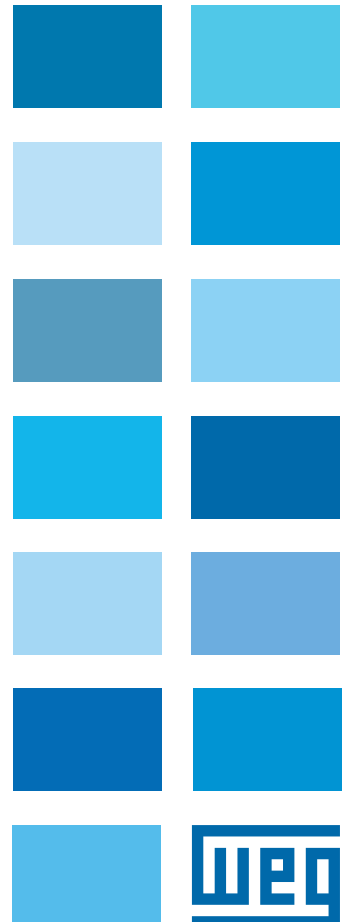
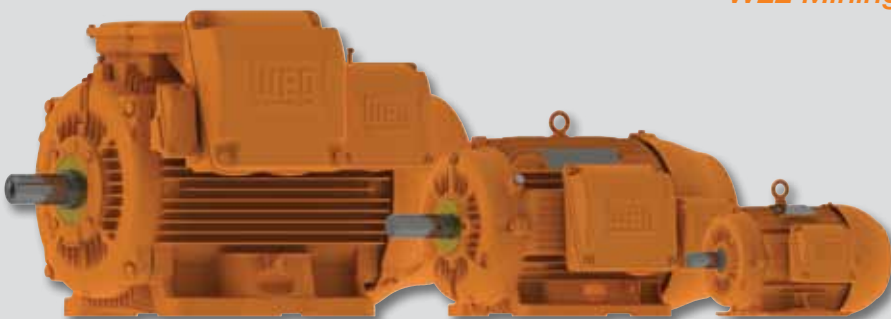



W22 Line – High Efficiency Motors

The increasing demand for electrical energy to sustain global development requires consistent heavy investments in power generation. In addition to complex medium and long term planning, these investments rely on natural resources, which are becoming depleted due to constant pressures upon the environment. The best sustainable strategy is to prevent wastage and increase energy efficiency. Electric motors play a major role in this strategy, for around 40% of all global energy demand is estimated to be related to electric motor applications. Consequently, any initiatives to increase energy efficiency, by using high efficiency electric motors and frequency inverters, are to be welcomed, as they can make a real contribution to reducing global energy demand and carbon emissions.

At the same time as efficiency initiatives make an impact in traditional market segments, the application of new technologies results in profound changes in the way electric motors are applied and controlled. By integrating these changes together with the demands for increased energy efficiency, WEG has taken up this global challenge and produced a new design of high efficiency motor; one that exceeds the performance of

WEG’s existing W21 line, which has been recognized worldwide for its quality, reliability and efficiency.

Combining engineering know-how to the latest generation of computerised tools, such as structural analysis (finite element analysis), fluid dynamics and electrical design optimization software, an innovative, next generation product range has been developed: the W22 motor.

Several key objectives have been achieved in the design of the W22 motor:

- Reduction of noise and vibration levels
- Increased energy efficiency and reduced thermal footprint
- Easy maintenance through robust modular design
- Compatibility with present & future generations of frequency inverters
- Low carbon emissions during manufacturing, installation and throughout its long operating life
- High torques keeping up with the toughest load and voltage oscillations.

W22 Industrial



W22 Mining



Frame 63 to 112

Frame 132 to 200

Frame 225 to 355



Sustainability and Carbon Footprint reduction through High Efficiency Motors

The High Efficiency (E3) level established in AS/NZS 1359.5-2004 or IE3 (IEC 60034-30: 2008) is considered the highest efficiency class which a squirrel cage induction motor can achieve whilst remaining economically viable. It is also the optimum solution to increase the efficiency of an existing application through direct replacement. So, why have High Efficiency motors not become the Industry standard?

It may be argued that high efficiency motors are available at a premium price when compared to standard efficiency (IE1) and minimum efficiency (MEPS/IE2) motors.

Whilst this is not strictly untrue, it should be appreciated that the cost of acquisition typically represents only 1% of the total cost of ownership of an electric motor. In conclusion, the associated energy savings provided by high efficiency motors far outweigh this additional investment in purchase price.

Furthermore the reduction in CO₂ emissions is one of the direct consequences, and therefore benefits, of increasing efficiency in industry.

According to the guidelines set out by the International Energy Agency (IEA), which estimates 504kg of CO₂ emissions per 1,000kWh, it is possible to reduce CO₂ emissions by approximately 1,000kg per year with one 3kW high efficiency motor and by 25,000kg per year with a 250kW high efficiency motor, when compared to equivalent standard efficiency MEPS (IE2) machines.

The **all round design** of the W22 range **reduces carbon emissions** from manufacturing to installation, inventory holdings and ongoing operation. **Extra low noise levels** will reduce compliance costs with OH&S requirements. **High torques** help keep your plant up and running. This is what we call **improving total efficiency**.

Visit www.weg.net/green to check the potential reduction in CO₂ emissions and the return on investment achieved with W22 High Efficiency motors.

The W22 line from WEG is the first complete range of E3, high efficiency, low carbon footprint motors available to Industry...

...we call it **WEGnology**

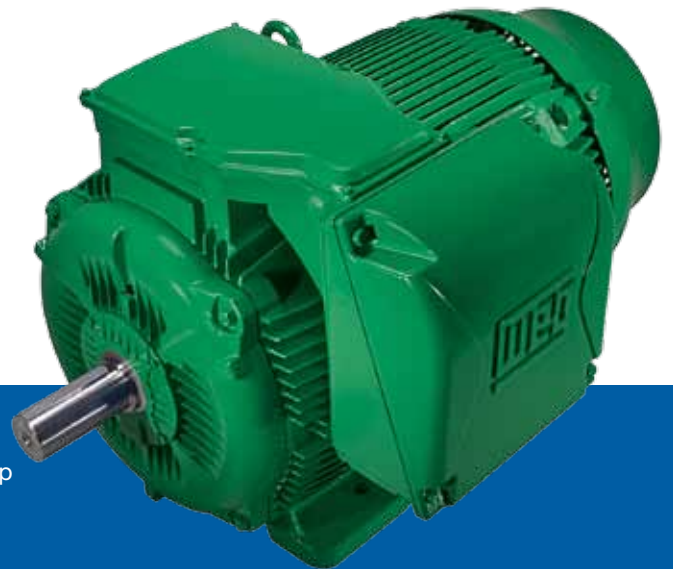

The WEG W22 is what the industrial world needs today, to help sustain its future – tomorrow.
Visit www.weg.net/w22 to find out more.

Minimum Energy Performance Standards

Increasingly the world seeks a path of sustainability and innovative ways to reduce energy consumption. A significant percentage of the electrical energy utilised in facilities around the world is transformed by electric motors. Consequently, governments are implementing Energy Efficiency Programs in order to enforce the use of high efficiency motors.

Prior to 2002, Australia did not have specific regulations relating to energy efficiency levels of electric motors. In April 2002 the Australian Green House Office introduced the MEPS regulation, AS/NZS 1359.5-2000 mandating efficiency levels of single-speed motors from 0.75kW to 160kW. In 2006, higher efficiency levels came into force with a revision of AS/NZS 1359.5.

Scope

The Scope of the Australian 1359.5 standard covers single speed, three-phase, 50Hz, squirrel cage induction motors that:

- have 2 to 8 poles
- have a rated voltage up to 1,100V
- have a rated output P_N between 0.75kW and 160kW
- are rated on the basis of continuous duty operation

Effective dates

- from 1st April 2006, all motors manufactured or imported into Australia shall not be less efficient than the MEPS efficiency level defined in AS/NZS 1359.5-2004
- high efficiency motors must also meet minimum efficiency levels

Rated Output kW	Minimum Efficiency MEPS - Test Method B*				Minimum HIGH Efficiency - Test Method B*			
	POLE				POLE			
	2	4	6	8	2	4	6	8
0.75	80.5	82.2	77.7	73.5	82.9	84.5	80.4	76.5
1.1	82.2	83.8	79.9	76.3	84.5	85.9	82.4	79.1
1.5	84.1	85.0	81.5	78.4	86.2	87.0	83.8	81.0
2.2	85.6	86.4	83.4	80.9	87.5	88.2	85.5	83.3
3	86.7	87.4	84.9	82.7	88.5	89.1	86.9	84.9
4	87.6	88.3	86.1	84.2	89.3	89.9	87.9	86.2
5.5	88.5	89.2	87.4	85.8	90.1	90.7	89.1	87.7
7.5	89.5	90.1	88.5	87.2	90.9	91.5	90.1	88.9
11	90.6	91.0	89.8	88.8	91.9	92.2	91.2	90.3
15	91.3	91.8	90.7	90.0	92.5	92.9	92.0	91.4
18.5	91.8	92.2	91.3	90.7	92.9	93.3	92.5	92.0
22	92.2	92.6	91.8	91.2	93.3	93.6	92.9	92.4
30	92.9	93.2	92.5	92.1	93.9	94.2	93.6	93.2
37	93.3	93.6	93.0	92.7	94.2	94.5	94.0	93.7
45	93.7	93.9	93.5	93.2	94.6	94.8	94.4	94.2
55	94.0	94.2	93.9	93.7	94.9	95.0	94.8	94.6
75	94.6	94.7	94.4	94.4	95.4	95.5	95.2	95.2
90	94.8	95.0	94.8	94.7	95.5	95.7	95.5	95.5
110	95.1	95.3	95.1	95.1	95.8	96.0	95.8	95.8
132	95.4	95.5	95.4	95.4	96.1	96.1	96.1	96.1
150	95.5	95.7	95.6	95.7	96.1	96.3	96.2	96.3
160	95.5	95.7	95.6	95.7	96.1	96.3	96.2	96.3

Table 1 - Efficiency levels as per AS/NZS 1359.5:2004

Notes:

*Based on AS/NZS 1359.5:2004

**For intermediate values of rated output, the efficiency shall be determined by linear interpolation



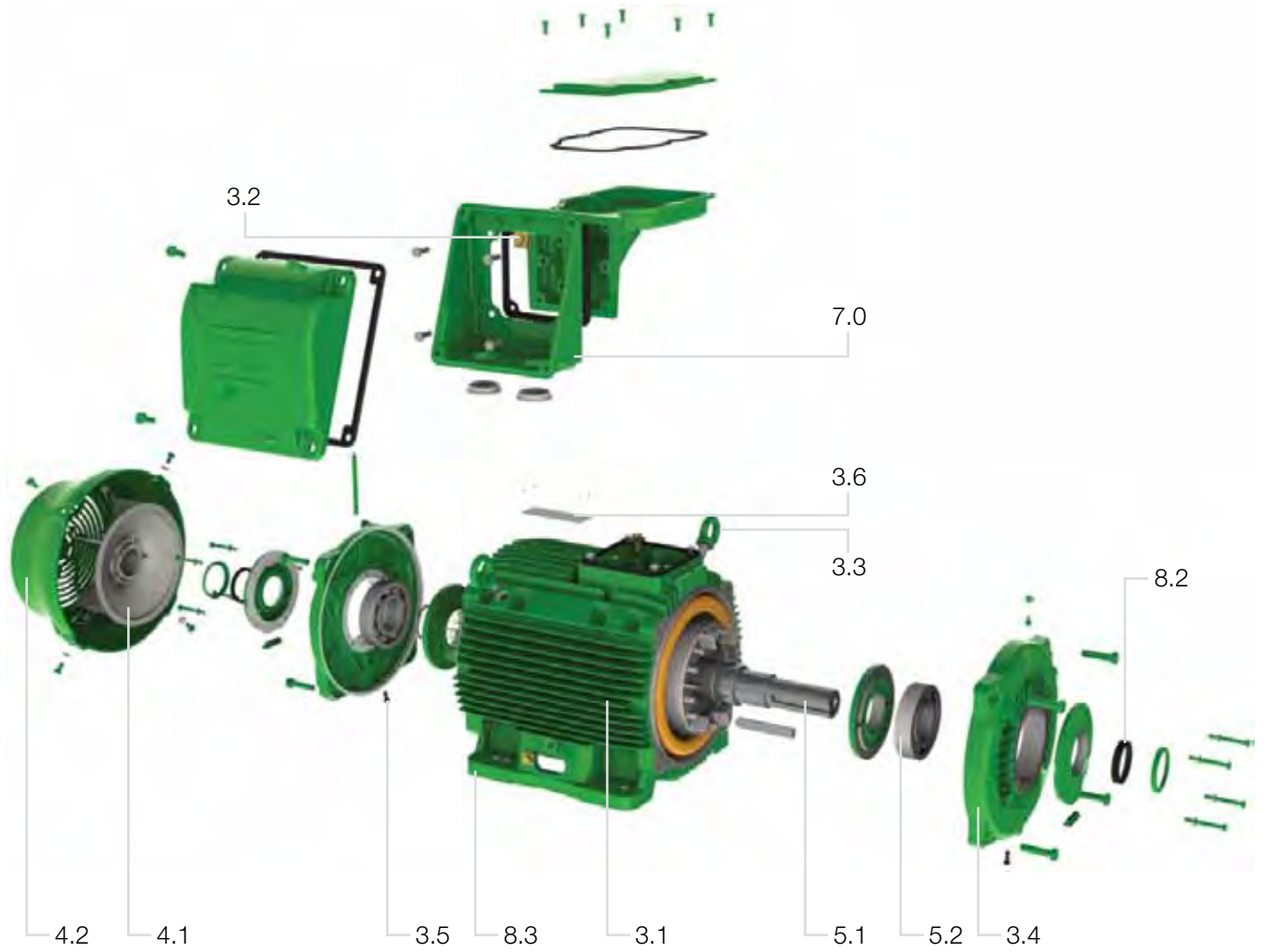

Table of Contents Item Number	Description	Page Number
3.1	Frame	Page 8
3.2	Grounding lugs	Page 9
3.3	Eyebolts	Page 9
3.4	Endshields	Page 9
3.5	Drain plugs	Page 10
3.6	Nameplate	Page 10
4.1	Cooling system	Page 10
4.2	Fan cover	Page 11
5.1	Shaft	Page 12
5.2	Bearings	Page 12
7.0	Terminal box	Page 16
8.2	Sealing system	Page 17
8.3	Painting	Page 17

Table 2 - Visual Index



Table of contents

1. Ranges available.....	7
2. Standards.....	7
3. Construction details.....	8
3.1 Frame.....	8
3.2 Earth terminals.....	9
3.3 Eyebolts.....	9
3.4 Endshields.....	9
3.5 Drain plugs.....	10
3.6 Nameplate.....	10
4. Cooling system / Noise level / Vibration level / Impact resistance.....	10
4.1 Cooling system.....	10
4.2 Fan cover.....	11
4.3 Impact resistance.....	11
4.4 Noise level.....	11
4.5 Vibration level.....	12
5. Shaft / Bearings / Thrusts.....	12
5.1 Shaft.....	12
5.2 Bearings.....	12
5.3 Thrusts.....	13
6. Mounting.....	15
7. Terminal box / Terminal block.....	16
7.1 Main terminal box.....	16
7.2 Main terminal block.....	16
7.3 Accessories terminal block.....	17
8. Degree of protection / Sealing system / Painting.....	17
8.1 Degree of protection.....	17
8.2 Sealing system.....	17
8.3 Painting.....	17
9. Voltage / Frequency.....	18
10. Overload capacity.....	18
10.1 Constant overload.....	18
10.2 Momentary overload capacity of 150%.....	18
11. Ambient x Insulation.....	18
12. WISE® Insulation system.....	19
12.1 Spike resistant wire.....	19
12.2 Class H.....	19
12.3 Temperature Rise.....	19
13. Motor Protection.....	19
13.1 Space heaters.....	20
13.2 Protection based on operating temperature.....	20
13.3 Protection based on operating current.....	21
14. Application with Variable Frequency Drives.....	21
14.1 Considerations regarding rated voltage.....	21
14.2 Torque restrictions on variable frequency drive applications.....	21
14.3 Optimal Flux®.....	21
14.4 Torque derating with Optimal Flux®.....	22
14.5 Bearing currents.....	22
14.6 Forced ventilation kit.....	23
14.7 Encoders.....	23
14.8 Minimum distance between fan cover and wall.....	23
15. Performance data.....	24-27
16. Mechanical data.....	28-32
17. Terminal box drawings.....	33
18. Rainhood.....	34
19. Packaging.....	34
20. Spare Parts.....	36-38

1. Ranges Available

W22 motors are available in two efficiency levels: High Efficiency E3 and Super High Efficiency E3 Plus (exceeds HEFF levels, not yet classed by AS 1359.5).

In figure 1 the efficiency levels of W22 E3 High Efficiency motors can be compared with the levels established by AS 1359.5-2004. W22 E3+ motors have even higher efficiencies.

In terms of mechanical features and accessories, W22 motors are available in general purpose (industrial motor) and mining (heavy duty) design.

W22 Product Ranges		
Product Ranges within the W22 Family	Efficiency	W22 E3 *
		W22 E3+ **
	Features	Industrial
		Mining

Table 3 - W22 Product Ranges

* Standard

** Optional

W22 motors are fully tested and have their efficiency figures declared in accordance with Test Method B with stray load losses determined as 0.5% of the output power.

2 Pole

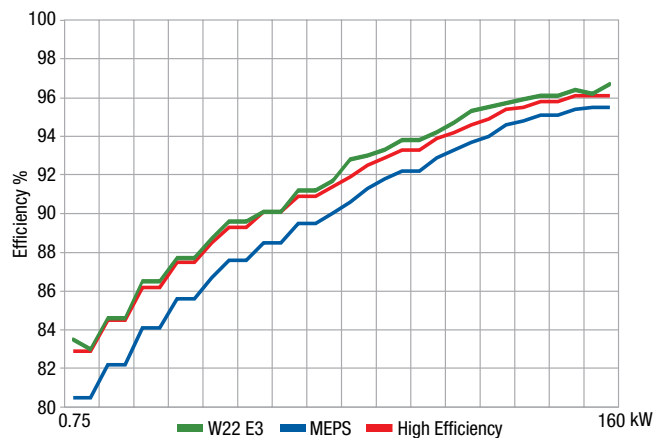

4 Pole

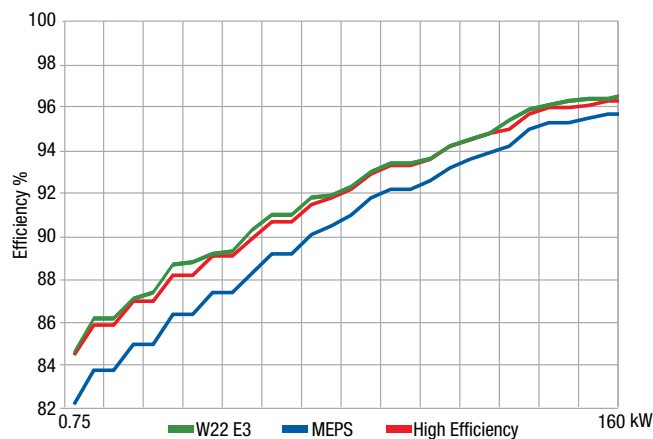

6 Pole

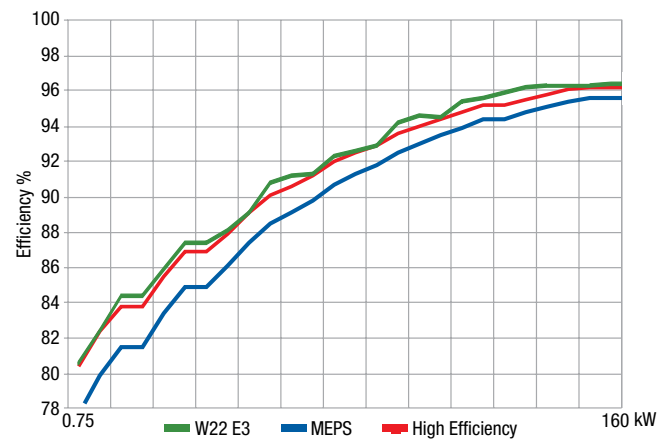

8 Pole

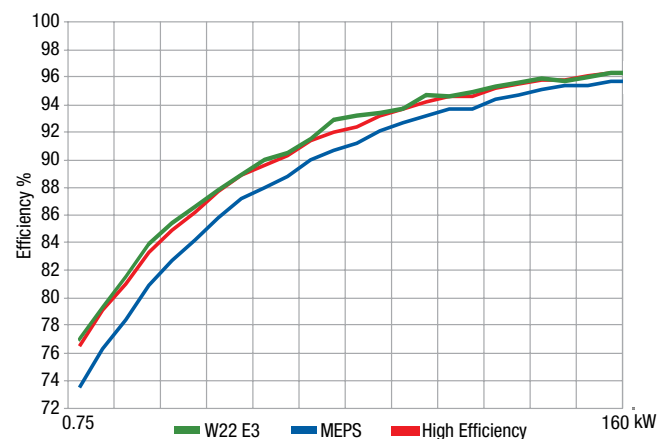

Figure 1

The W22 line was designed in such a way as to maintain virtually constant efficiencies over a 75% to 100% load range. Therefore, even considering industry over-sizing practices, high levels of energy efficiency are achieved (see figure 2).

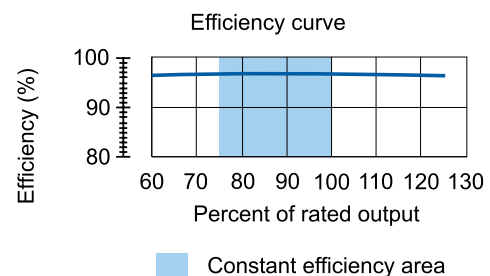

Figure 2 - Typical efficiency curve of W22 line

2. Applicable Standards

W22 motors meet the requirements and regulations of latest version of the following Standards:

- AS 60034.1
Rotating electrical machines - Rating and Performance
- IEC 60034-2-1
Rotating electrical machines – Standard methods for determining losses and efficiency from tests (excluding machines for traction vehicles)

- AS 60034.5
Rotating electrical machines - Degrees of protection provided by the integral design of rotating electrical machines (IP code) – Classification
- IEC 60034-6
Rotating electrical machines – Methods of cooling (IC code)
- AS 60034.7
Rotating electrical machines - Classification of types of construction, mounting arrangements and terminal box position (IM code)
- AS 60034.8
Rotating electrical machines - Terminal markings and direction of rotation
- AS 60034.9
Rotating electrical machines - Noise limits
- AS 60034.11
Rotating electrical machines - Thermal protection
- AS 60034.12
Rotating electrical machines - Starting performance of single-speed three-phase cage induction motors
- IEC 60034-14
Rotating electrical machines – Mechanical vibration of certain machines – Limits of vibration
- IEC 60034-30
Rotating electrical machines – Efficiency classes for single-speed three-phase cage induction motors
- IEC 60072-1
Dimensions and output series for rotating electrical machines – Frame numbers 56 to 400 and flange numbers 55 to 1080
- AS1359.102
Rotating electrical machines – General Requirement - Methods for determining losses and efficiency – General
- AS/NZS 1359.102.3
Rotating electrical machines – General - Methods for determining losses and efficiency – Three phase cage induction motors
- AS/NZS 1359.5
Rotating electrical machines – Three phase cage induction motors – High efficiency and minimum efficiency performance standards (MEPS) requirements

For compliance with other standards or technical specifications, please contact WEG.

3. Construction details

The information included in this document refers to standard construction features and the most common variations for W22 motors. Where specified, some features may apply to a range of frame sizes, e.g. IEC 225S/M to 355M/L. Customised W22 motors for special applications are available on request. For more information, please contact your nearest WEG office or WEG business partner.

3.1 Frame



Figure 3 - W22 Frame

WEG motors are made of high grade cast iron material. There are basically three densities used in manufacturing electric motors: FC-100 (the industry standard), FC-150 and FC-200. **WEG uses exclusively FC-200, the same grade mandated by international standards for explosion proof motors,** providing high levels of mechanical strength, adequate for the most severe applications.

The frame was designed in such a way as to minimize air flow dispersion and improve heat dissipation (see figure 4) resulting in less hot spots on the frame and longer bearing lubrication intervals.

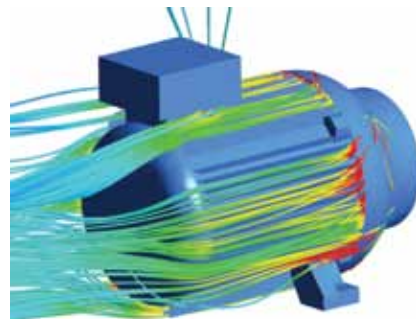

Figure 4 - Air flow demonstration for W22 motors.

The cooling fins have been designed to avoid accumulation of liquids and solid particles over the motor. The motor feet are completely solid for enhanced mechanical strength and easy alignment and installation.



Figure 5 - Solid feet

To facilitate condition monitoring, frames 225 to 355 have been designed with flat areas on both ends for better placement of accelerometers. These are available in both vertical and horizontal planes (figure 6). In addition, mining motors have SPM mounting studs in frames 160 to 355 (figure 7).

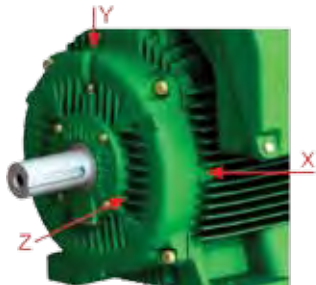

Figure 6 - Flat surfaces for vibration checking on the DE side (frames 225 to 355)



Figure 7 - Flat surfaces for vibration checking (frames 225 to 355)

3.2 Earth terminals

The frame of all W22 motors comprises two grounding points for increased levels of safety. These are conveniently located, one directly below the main terminal box, the other on the opposite side of the frame (Refer Figure 8).

In addition, two more grounding points are located within the terminal box, adjacent to the terminal block (Refer Figure 9).



Figure 8 - Grounding lugs position on the frame.



Figure 9 - Earth terminals in the terminal box

3.3 Eyebolts

Eyebolts are provided as standard from frame size 100L and above and have been designed so as not to interfere with the motor's IP66 rating. The W22 frame, version B3, is fitted with two eyebolts for lifting on its uppermost face. These have been designed not to interfere with the air flow. The position of the eyebolts is shown in table 4.

Number of eyebolts	Description
1	Frames 100L to 200L Motors with feet and with side mounted terminal box
2	Frames 100L to 200L Motors with feet and with top mounted terminal box
2	Frames 100L to 200L – Motors without feet and with C or FF flange
2	Frames 225S/M to 355 – Motors with feet and side or top mounted terminal box. These motors have four threaded holes in the upper part of the frame for fastening of the eyebolts (figure 10)
2	Frames 225S/M to 355 – Motors without feet and with C or FF flange. These motors have four threaded holes in the upper part of the frame for fastening of the eyebolts and two more threaded holes in the bottom part

Table 4 - Eyebolts

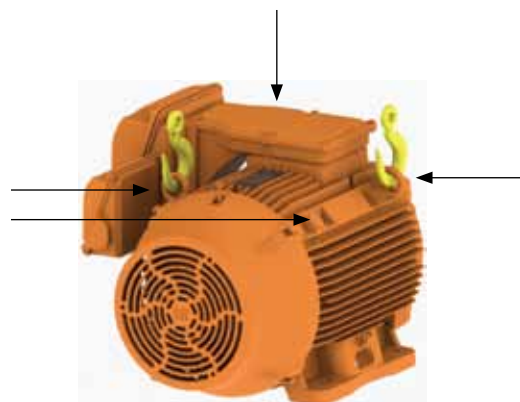

Figure 10 - Fastening locations for the eyebolts

3.4 Endshields

The drive end shield is designed with fins and reinforced structure for better heat dissipation and to ensure low bearing operating temperatures. This results in extended lubrication intervals and subsequently lower on-going costs.

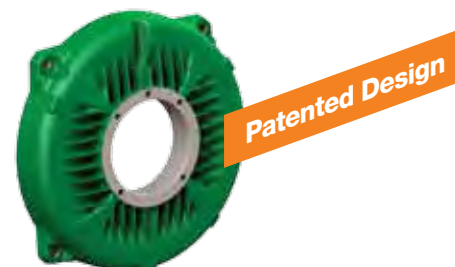

Figure 11 - Drive end endshield



Figure 12 - Non-drive endshield

3.5 Drain plugs

All endshields have been designed with drain holes to allow drainage of condensed water. Drain holes are fitted with rubber plugs and comply with IP55 degree of protection in conformance with IEC 60034-5 (when opened). The same plugs can also be closed to ensure a higher IP66 degree of protection.

These plugs leave the factory in the closed position and must be opened periodically to allow drainage of condensed water. Drain plugs in frames 63 to 132 are of the automatic type and made of plastic. Alternatively, porous drain plugs are available.

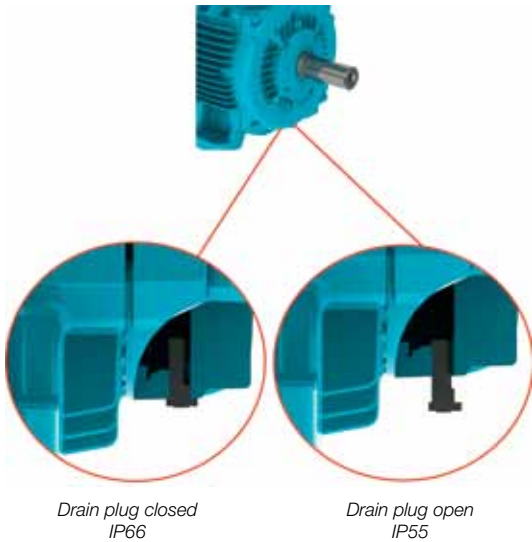

Figure 13 - Detail of the drain plug position on the drive endshield (frames 160-355)

3.6 Nameplate

The nameplate contains complete information on motor construction and performance characteristics. It is made of stainless steel AISI 304 as shown in figure 14.

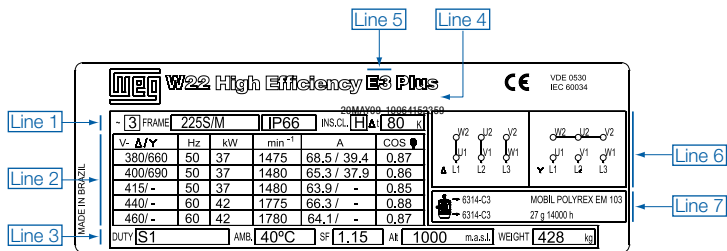

Figure 14 - Nameplate for multi-voltage design



Figure 15 - Nameplate for multi-voltage design.

Line 1:

~ AC
3 Three phase
225S/M Frame size
IP66 Degree of protection
INS. CL. H Insulation class: H
Δt Temperature rise: ≤80 K

Line 2:

V Rated operating voltage
Hz Frequency
kW Motor rated power
Min⁻¹ Motor rated speed RPM
A Rated operating current
cos φ Power factor

Line 3:

DUTY Duty cycle: S1
AMB Ambient temperature: 40°C
SF. Service factor: 1.15
Alt Altitude: 1000 m.a.s.l.
WEIGHT Motor weight: 428 kg

Line 4:

Manufacturing date and serial number

Line 5:

Efficiency Level

Line 6:

Δ Connection diagram for rated voltage of 380, 400, 415, 440, 460 V
Y Connection diagram for 690 V

Line 7:

6314-C3 Non-drive end bearing specification
6314-C3 Drive end bearing specification
MOBIL POLYREX EM 103 Type of grease
27 g 1400 hrs Amount of grease (g) and re-lubrication interval in hours (hrs)

4. Cooling System / Noise Level / Vibration Level / Impact Resistance

4.1 Cooling system

W22 motors are totally enclosed fan cooled (IC411), as per IEC 60034-6. Other versions such as non-ventilated (TENV), air over (TEAO) or forced ventilated TEFV (IC416) are available on request. More information about IC416 option can be found in chapter 14, which describes operation with variable frequency drives.

Fans are bidirectional and made of polypropylene (W22 Industrial) or cast iron (W22 mining range), as per table 5.

	Pole	Fan Material		
		63-315S/M	315L-355M/L	355A/B
W22 General Purpose	2	Plastic	Plastic	Aluminium
	4		Aluminium	
	6	Plastic		
	8			
W22 Mining	2-8 pole	FC-200 Cast Iron		

Table 5 - Fan material



Figure 16 - Cooling system

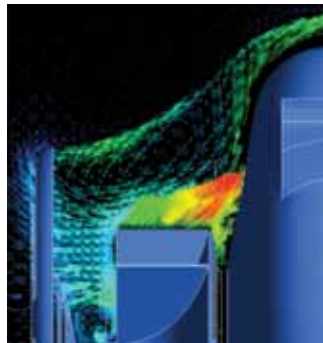

Figure 17 - Cooling system operation

The cooling system (fan, non drive endshield and fan cover) was designed to minimize the noise level and improve thermal efficiency.

4.2 Fan cover

Made of FC-200 cast iron or pressed steel, the fan cover has an aerodynamic design, which results in a significant reduction of noise level and optimized air flow for improved heat dissipation (see figure 18).



Figure 18 - Fan cover

Patented Design

Benefits:

- Superior mechanical rigidity
- Corrosion-resistant
- Low noise operation

Frames	Fan Cover Material		
	63 - 80	90 - 132	160 - 355
W22 Industrial	Steel	Steel	Cast Iron
W22 Mining	Steel	Cast Iron	Cast Iron

Table 6 - Fan cowl material

4.3 Impact resistance

W22 motors with cast iron fan cover comply with impact level IK08 – mechanical impact of 5J as per EN 50102 (Degree of protection provided by enclosures for electrical equipment against external mechanical impacts IK code), ensuring superior mechanical strength for the most demanding applications.

4.4 Noise level

W22 motors comply with AS 60034.9 Standard and its corresponding sound pressure levels. Tables 7 and 8 show sound pressure levels, in dB(A), obtained from tests at 50 and 60 Hz.

Frame	IEC 50 Hz			
	Sound pressure level - dB(A)			
	2 Poles	4 Poles	6 Poles	8 Poles
63	52	44	43	-
71	56	43	43	41
80	59	44	43	42
90	62	49	45	43
100	67	53	44	50
112	64	56	48	46
132	67	56	52	48
160	67	61	56	51
180	67	61	56	51
200	69	63	60	53
225	74	63	61	56
250	74	64	61	56
280	77	69	65	59
315S/M	77	71	67	61
315 L	78	73	68	61
355M/L	80	74	73	70

Table 7 - Sound pressure levels for 50Hz motors, tested as per AS 60034.9.

Frame	IEC 60 Hz			
	Sound pressure level - dB(A)			
	2 Poles	4 Poles	6 Poles	8 Poles
63	56	48	47	-
71	60	47	47	45
80	62	48	47	46
90	68	51	49	47
100	71	54	48	54
112	69	58	52	50
132	72	61	55	52
160	72	64	59	54
180	72	64	59	54
200	74	66	62	56
225	79	67	64	60
250	79	68	64	60
280	81	73	69	63
315S/M	81	75	70	64
315 L	82	77	71	64
355M/L	84	78	77	75

Table 8 - Sound pressure levels for 60Hz motors.

The noise level figures shown in tables 7 and 8 are taken at no load. Under load AS 60034.9 standard estimates an increase in the sound pressure levels as shown in table 9.

Frame (mm)	2 poles	4 poles	6 poles	8 poles
90 ≤ H ≤ 160	2	5	7	8
180 ≤ H ≤ 200	2	4	6	7
225 ≤ H ≤ 280	2	3	6	7
H = 315	2	3	5	6
H ≥ 355	2	2	4	5

Table 9 - Maximum expected increase in sound pressure level for motors at full load.

Noise levels can be further reduced by up to 2 dB(A) with the installation of a rainhood/canopy.

4.5 Vibration level

W22 motors are dynamically balanced with half key to Grade A as per IEC 60034-14 standard. As an option, motors can be supplied in conformance with Grade B. The RMS vibration levels in mm/s of Grades A and B are shown in table 10.

	Frame	56 ≤ H ≤ 132	132 < H ≤ 280	H > 280
	Assembly	Vibration level RMS (mm/s)	Vibration level RMS (mm/s)	Vibration level RMS (mm/s)
Grade A	Free suspension	1.6	2.2	2.8
Grade B	Free suspension	0.7	1.1	1.8

Table 10 - Maximum vibration levels.

5. Shaft / Bearings / Thrusts

5.1 Shaft

The shaft of W22 Industrial motors is made of AISI 1040/45 Steel or AISI 4140 (355 frame). When supplied with roller bearings (factory ordered), the shaft material is AISI 4140.

All W22 **Mining motors** in frames 225 to 355 **have high tensile AISI 4140 shaft** by default.

Shafts are supplied with open profile keyway (type B) and with dimensions shown in section 16 – Mechanical data.

Standard Shaft Material			
Frames	63 - 200	225 - 315	355
W22 Industrial	1040 / 1045	1040 / 1045	4140
W22 Mining	1040 / 1045	4140	4140

Table 11 - Shaft material

5.2 Bearings

W22 Industrial motors are supplied with ball bearings in all frames.



Figure 19 - Bearing View

W22 mining motors, in frames 225 to 355, have roller bearings, making them suitable for heavy duty applications including pulley and belts. Information about maximum allowable radial and axial loads on shaft ends is given in tables 14, 15 and 16.

D.E. Bearing		
Frames	63 - 200	225 - 355
W22 Industrial	Ball Bearing	Ball Bearing
W22 Mining	Ball Bearing	Roller Bearing *

Table 12

*Excluding 2 pole motors which are supplied with ball bearings.

Bearing life L₁₀ is as described in tables 14, 15 and 16. When direct coupled to the load (without axial or radial thrusts), the L₁₀ bearing life exceeds 100,000 hours.

Note: The radial force value Fr can be inferred from information in catalogues of pulley/belt manufacturers. When this information is not available, the force Fr under operation can be calculated based on the output power, coupling design characteristics and application.

$$Fr = \frac{19.1 \times 10^6 \times P_n}{n_n \times dp} \times ka \text{ (N)}$$

Where:

Fr is the radial force exerted by the pulley and belt coupling [N];

P_n is the motor rated power [kW];

n_n is the motor rated speed [rpm];

dp is the pitch diameter of the driven pulley [mm];

ka is a factor that depends on the extent of pulley elongation and type of application.

Groups and Basic Types of Application		ka Factor of the application	
		V-Belts	Plain Belts
1	(Fans and Blowers. Centrifugal Pumps. Winding machines. Compressors. Machine tools) with outputs up to 30 HP (22 kW)	2.0	3.1
2	(Fans and Blowers, Centrifugal Pumps, Winding machines, Compressors, Machine tools) with outputs higher than 30 HP (22 kW), Mixers, Plungers, Printer Machines.	2.4	3.3
3	Presses, vibrating screens, Piston and screw compressor, pulverisers, helicoidal conveyors, woodworking machines, Textile machines, Kneading machines, Ceramic machines, Pulp and paper industrial grinders.	2.7	3.4
4	Overhead cranes, Hammer mills, Metal laminators, Conveyors, Gyrotory Crushers, Jaw Crusher, Cone Crushers, Cage Mills, Ball Mills, Rubber Mixers, Mining machines, Shredders.	3.0	3.7

Table 13 - ka factor

Bearing life depends upon several factors such as on the type and size of the bearing, on the radial and axial mechanical loads applied to the bearing, on the operating conditions (ambient temperature), on the quality and amount of grease, the speed at which the bearing is used, and the maintenance and re-lubrication procedures in place.

W22 motors (frames 160 to 355) are supplied with greasing system on drive end and non-drive end shields for in service bearing lubrication. The quantity of grease to be used and lubrication intervals are given on the nameplate; they are also shown in tables 17 and 18.

Note: Excessive amount of grease can increase bearing temperature and consequently reduce bearing life.

When fitted with ball bearings, the drive end bearing is located axially and the non-drive end bearing is fitted with pre-loading springs. When supplied with roller bearing, the non-drive end bearing is located and the thermal expansion takes place within the axial clearance of the drive end roller bearing.

Notes:

1 - Special applications

Non-standard motor operation such as low/high ambient temperatures, high altitude, high axial or radial loads require specific lubrication measures and different lubrication intervals from those provided in the tables included in this technical catalogue.

2 - Roller bearings

Roller bearings require a minimum radial load to ensure correct operation. They are not suitable for direct coupling arrangements or for 2 pole motors.

3 - VSD driven motors

Bearing life may be reduced when a motor is driven by frequency drive above its rated speed. Speed itself is one of the factors taken into consideration when determining bearing life. Bearing insulation may be needed, please refer to item 14.5 for more information.

4 - Motors with modified mounting configurations

For motors supplied for horizontal mounting but installed vertically, lubrication intervals must be reduced by half.

5 - Figures for radial thrusts

The figures given in the tables below for radial thrusts take into consideration the point where the load is applied which is on the centre of the shaft end length (L/2), or on the very end of the shaft end (L)



Figure 20 - Radial and axial thrust on motor shaft

5.3 Thrusts

Radial thrust - Ball bearing on drive end

Maximum permissible radial thrust - 50 Hz – Fr in (kN) L10 ≥ 20,000 hours								
Frame	2 poles		4 poles		6 poles		8 poles	
	L	L/2	L	L/2	L	L/2	L	L/2
63	0.4	0.3	0.4	0.3	0.4	0.3	0.4	0.3
71	0.5	0.5	0.6	0.5	0.6	0.5	0.7	0.6
80	0.6	0.6	0.7	0.7	0.8	0.7	1.0	0.8
90	0.7	0.6	0.8	0.7	0.9	0.8	1.0	0.9
100	0.9	1.0	1.0	1.1	1.2	1.3	1.3	1.4
112	1.2	1.3	1.4	1.5	1.6	1.8	1.7	1.9
132	1.8	2.0	2.2	2.4	2.4	2.7	2.6	2.9
160	2.3	2.6	2.6	2.9	2.7	3.3	2.7	3.7
180	3.1	3.5	3.6	4.0	4.2	4.7	4.2	5.2
200	3.7	4.0	4.2	4.7	4.9	5.4	5.7	6.2
225	5.1	5.5	5.2	6.3	5.3	7.0	5.7	8.1
250	4.9	5.3	5.2	5.7	6.5	7.1	6.0	8.2
280	5.0	5.4	6.7	7.2	7.8	8.4	8.7	9.4
315S/M	4.3	4.7	7.0	7.7	8.1	8.8	9.0	9.8
315 L	4.6	5.0	4.0	7.3	6.2	8.2	9.1	9.8
355M/L	4.8	5.1	8.5	9.3	9.6	10.4	11.6	12.6

Table 14.1 - Maximum permissible radial thrusts for ball bearings

Radial thrust - Ball bearing on drive end

Maximum permissible radial thrust - 50 Hz – Fr in (kN) L10 ≥ 40,000 hours								
Frame	2 poles		4 poles		6 poles		8 poles	
	L	L/2	L	L/2	L	L/2	L	L/2
63	0.2	0.2	0.3	0.3	0.4	0.3	0.4	0.3
71	0.3	0.3	0.4	0.4	0.5	0.5	0.6	0.5
80	0.5	0.5	0.6	0.5	0.6	0.6	0.7	0.7
90	0.5	0.5	0.6	0.5	0.7	0.6	0.8	0.7
100	0.7	0.7	0.7	0.8	0.9	1.0	1.0	1.1
112	0.9	1.0	1.0	1.1	1.2	1.4	1.3	1.4
132	1.4	1.6	1.6	1.8	1.8	2.0	2.0	2.2
160	1.8	2.0	1.9	2.1	2.2	2.4	2.5	2.7
180	2.4	2.7	2.7	3.0	3.2	3.5	3.6	3.9
200	2.8	3.0	3.2	3.5	3.7	4.0	4.3	4.7
225	3.9	4.3	4.3	4.7	4.7	5.2	5.6	6.2
250	3.7	4.1	3.8	4.2	4.9	5.4	5.7	6.3
280	3.8	4.1	4.9	5.4	5.8	6.3	6.5	7.0
315S/M	3.1	3.4	4.9	5.4	5.7	6.2	6.3	6.9
315 L	3.4	3.6	4.0	4.9	5.1	5.5	6.4	6.9
355M/L	3.3	3.6	5.8	6.3	6.5	7.1	8.2	8.9

Table 14.2 - Maximum permissible radial thrusts for ball bearings

Radial thrust - Roller bearing on drive end

Maximum permissible radial thrust - 50 Hz - Fr in (kN) L10 ≥ 40,000 hours						
Frame	4 poles		6 poles		8 poles	
	L/2	L	L/2	L	L/2	L
160	5	3.2	5.1	3.3	5.1	3.3
180	8.8	5.5	8.8	5.6	8.8	5.6
200	11.2	7.3	11.2	7.4	11.3	7.4
225S/M	12.9	7.6	12.9	7.6	13	7.8
250S/M	20.9	12.9	22.8	13	25.2	13.1
280S/M	25.4	14	27.5	14.2	27.5	14.3
315S/M	25.4	15.3	27.4	15.4	27.6	16.2
315 L	25.2	13	26.1	12.5	27	14.7
355M/L	34	17.3	33.5	16.4	33.5	16.1
355A/B	31.4	14.9	35.4	12	28.4	13.5

Table 15 - Maximum permissible radial thrusts for roller bearings

Note: the figures given for roller bearings take into consideration shaft supplied with steel AISI 4140

Axial thrust - Ball bearing on drive end

Maximum permissible axial thrust - 50 Hz - Fa in (kN) - L10 ≥20,000 hours							
Frame	Poles	Horizontal		Vertical with shaft upwards		Vertical with shaft downwards	
		Pushing	Pulling	Pushing	Pulling	Pushing	Pulling
63	2	0.2	0.2	0.2	0.2	0.2	0.2
	4	0.3	0.3	0.3	0.3	0.3	0.3
	6	0.3	0.4	0.3	0.4	0.4	0.3
	8	0.3	0.4	0.3	0.4	0.4	0.3
71	2	0.2	0.3	0.2	0.3	0.2	0.3
	4	0.3	0.4	0.3	0.4	0.3	0.4
	6	0.4	0.5	0.4	0.5	0.4	0.5
	8	0.5	0.6	0.4	0.6	0.5	0.6
80	2	0.3	0.4	0.3	0.4	0.3	0.4
	4	0.4	0.6	0.3	0.6	0.4	0.5
	6	0.5	0.7	0.4	0.7	0.5	0.7
	8	0.6	0.8	0.5	0.9	0.6	0.8
90	2	0.4	0.4	0.3	0.5	0.4	0.4
	4	0.5	0.6	0.5	0.7	0.5	0.6
	6	0.6	0.7	0.6	0.8	0.6	0.7
	8	0.8	0.9	0.7	0.9	0.8	0.8
100	2	0.4	0.6	0.3	0.7	0.4	0.6
	4	0.5	0.8	0.4	0.9	0.5	0.8
	6	0.7	1.0	0.6	1.1	0.7	1.0
	8	0.8	1.2	0.7	1.3	0.8	1.1
112	2	0.5	0.8	0.5	0.9	0.6	0.7
	4	0.7	1.1	0.7	1.2	0.8	1.0
	6	1.0	1.4	0.9	1.5	1.0	1.3
	8	1.1	1.5	1.0	1.7	1.1	1.4
132	2	0.7	1.3	0.6	1.5	0.8	1.2
	4	1.0	1.8	0.8	2.1	1.0	1.7
	6	1.2	2.2	1.1	2.5	1.3	2.1
	8	1.4	2.5	1.2	2.8	1.4	2.3
160	2	2.4	1.7	0.2	2.1	2.8	1.5
	4	3.0	2.3	2.7	2.7	3.4	2.0
	6	3.4	2.7	3.1	3.3	4.0	2.4
	8	3.9	3.2	3.6	3.7	4.4	2.9
180	2	3.2	2.3	2.9	2.8	3.7	2.0
	4	3.9	3.0	3.6	3.7	4.6	2.7
	6	4.7	3.8	4.2	4.5	5.3	3.3
	8	5.2	4.4	4.8	5.1	6.0	3.9
200	2	3.6	2.6	3.1	3.3	4.3	2.1
	4	4.5	3.5	4.0	4.3	5.3	3.0
	6	5.2	4.2	4.7	5.1	6.1	3.7
	8	6.0	5.0	5.5	5.9	6.9	4.5
225	2	4.6	3.8	3.8	4.9	5.7	3.1
	4	5.8	5.0	5.0	6.3	7.1	4.2
	6	6.7	5.9	5.7	7.6	8.4	4.9
	8	7.8	7.0	6.9	8.5	9.3	6.1
250	2	4.5	3.7	3.7	4.9	5.6	3.0
	4	5.4	4.7	4.2	6.6	7.4	3.4
	6	6.8	6.0	5.4	8.0	8.8	4.6
	8	7.8	7.1	6.6	8.9	9.7	5.9
280	2	4.4	3.7	3.2	5.4	6.2	2.4
	4	6.3	5.5	4.6	8.0	8.8	3.9
	6	7.6	6.8	5.8	9.4	10.2	5.0
	8	8.5	7.8	6.6	10.6	11.4	5.8
315S/M	2	4.1	3.3	2.4	5.9	6.7	1.6
	4	6.8	6.0	4.3	10.0	10.7	3.5
	6	8.0	7.2	5.2	11.9	12.7	4.5
	8	9.1	8.3	6.2	13.2	14.0	5.5
315 L	2	3.0	2.2	1.1	5.0	5.7	0.4
	4	4.5	3.7	1.4	8.2	8.9	0.6
	6	5.2	4.4	1.9	9.5	10.3	1.2
	8	6.3	5.5	3.4	10.0	10.8	2.6
355M/L	2	4.4	3.7	1.1	8.8	9.5	0.3
	4	7.7	7.0	3.2	13.9	14.7	2.5
	6	9.1	8.4	4.7	15.3	16.0	3.9
	8	10.9	10.2	6.4	17.2	17.9	5.7

Table 16.1 - Maximum permissible axial thrusts for ball bearings.
Higher thrust levels can be achieved with thrust bearings.

Axial thrust - Ball bearings

Maximum permissible axial thrust - 50 Hz - Fa in (kN) - L10 ≥40,000 hours							
Frame	Poles	Horizontal		Vertical with shaft upwards		Vertical with shaft downwards	
		Pushing	Pulling	Pushing	Pulling	Pushing	Pulling
63	2	0.1	0.1	0.1	0.1	0.1	0.1
	4	0.2	0.2	0.2	0.2	0.2	0.2
	6	0.2	0.2	0.2	0.2	0.2	0.2
	8	0.2	0.2	0.2	0.2	0.2	0.2
71	2	0.1	0.2	0.1	0.2	0.1	0.2
	4	0.2	0.3	0.2	0.3	0.2	0.2
	6	0.2	0.3	0.2	0.3	0.2	0.3
	8	0.3	0.4	0.3	0.4	0.3	0.4
80	2	0.2	0.3	0.1	0.3	0.2	0.3
	4	0.2	0.4	0.2	0.4	0.2	0.3
	6	0.3	0.5	0.3	0.5	0.3	0.4
	8	0.4	0.6	0.3	0.6	0.4	0.5
90	2	0.2	0.3	0.2	0.3	0.2	0.2
	4	0.3	0.4	0.3	0.4	0.3	0.3
	6	0.4	0.5	0.4	0.5	0.4	0.4
	8	0.5	0.6	0.5	0.6	0.5	0.5
100	2	0.2	0.4	0.2	0.4	0.2	0.3
	4	0.3	0.5	0.2	0.6	0.3	0.5
	6	0.4	0.7	0.3	0.8	0.4	0.6
	8	0.5	0.8	0.4	0.9	0.5	0.7
112	2	0.3	0.5	0.3	0.6	0.3	0.4
	4	0.4	0.7	0.4	0.8	0.5	0.6
	6	0.6	0.9	0.5	1.1	0.6	0.8
	8	0.7	1.0	0.6	1.2	0.7	0.9
132	2	0.4	0.9	0.3	1.1	0.5	0.8
	4	0.6	1.2	0.5	1.4	0.6	1.1
	6	0.8	1.5	0.6	1.8	0.8	1.3
	8	0.9	1.7	0.7	2.0	0.9	1.5
160	2	1.8	1.1	1.6	1.5	2.2	0.9
	4	2.2	1.5	1.9	1.9	2.6	1.2
	6	2.5	1.8	2.2	2.3	3.1	1.5
	8	2.9	2.2	2.5	2.7	3.4	1.8
180	2	2.4	1.5	2.1	2.0	2.9	1.2
	4	2.9	2.0	2.5	2.6	3.5	1.6
	6	3.4	2.5	3.0	3.2	4.1	2.1
	8	3.9	3.0	3.5	3.7	4.6	2.6
200	2	2.7	1.7	2.2	2.4	3.4	1.2
	4	3.3	2.3	2.8	3.1	4.1	1.8
	6	3.8	2.8	3.3	3.8	4.8	2.3
	8	4.4	3.4	3.9	4.3	5.3	2.9
225	2	3.4	2.6	2.7	3.7	4.5	1.9
	4	4.2	3.5	3.4	4.7	5.5	2.6
	6	4.8	4.0	3.8	5.7	6.5	3.0
	8	5.7	4.9	4.8	6.4	7.1	4.1
250	2	3.4	2.5	2.5	3.7	4.5	1.8
	4	3.9	3.1	2.6	5.0	5.9	1.8
	6	4.9	4.1	3.6	6.2	7.0	2.8
	8	5.8	4.9	4.5	6.8	7.6	3.8
280	2	3.3	2.5	2.0	4.3	5.1	1.2
	4	4.6	3.8	2.9	6.2	7.0	2.1
	6	5.4	4.7	3.6	7.3	8.0	2.8
	8	6.1	5.4	4.2	8.2	9.0	3.4
315	2	2.9	2.2	1.2	4.8	5.5	0.4
	4	4.7	4.0	2.2	7.9	8.6	1.4
	6	5.6	4.8	2.8	9.4	10.2	2.0
	8	6.4	5.6	3.4	10.4	11.2	2.6
315 L	2	3.0	2.2	1.1	5.0	5.7	0.4
	4	4.5	3.7	1.4	8.2	8.9	0.6
	6	5.2	4.4	1.9	9.5	10.3	1.2
	8	6.3	5.5	3.4	10.0	10.8	2.6
355M/L	2	3.1	2.4	0.6	6.7	7.5	0.2
	4	5.5	4.7	1.9	1.1	11.6	1.2
	6	6.3	5.6	2.8	11.8	12.7	2.0
8	7.6	6.8	3.8	13.2	13.7	2.9	

Table 16.2 - Maximum permissible axial thrusts for ball bearings.
Higher thrust levels can be achieved with thrust bearings.

Lubrication intervals - Horizontal mounting

Frame	Poles	Lubrication intervals (hours)		
		Bearing	50 Hz	60 Hz
160	2	6309	22,000	20,000
	4		25,000	25,000
	6			
	8			
180	2	6311	17,000	14,000
	4		25,000	25,000
	6			
	8			
200	2	6312	15,000	12,000
	4		25,000	25,000
	6			
	8			
225	2	6314	5,000	4,000
	4		14,000	12,000
	6			
	8			
250	2	6314	5,000	4,000
	4		14,000	12,000
	6			
	8			
280	2	6314	5,000	4,000
	4	6316	13,000	10,000
	6		18,000	16,000
	8		20,000	20,000
315	2	6314	5,000	4,000
	4	6319	11,000	8,000
	6		16,000	13,000
	8		20,000	17,000
355	2	6314	5,000	4,000
		6316	4,000	N/A
	4	6322	9,000	6,000
	6		13,000	11,000
8	19,000		14,000	

Table 17 - Lubrication intervals for ball bearings at 70°C

Lubrication intervals - Horizontal mounting

Frame	Poles	Lubrication intervals (hours)		
		Bearing	50 Hz	60 Hz
160	4	NU309	25,000	25,000
	6			
	8			
180	4	NU311	25,000	25,000
	6			
	8			
200	4	NU312	25,000	21,000
	6			25,000
	8			
225	4	NU314	11,000	9,000
	6		16,000	13,000
	8		20,000	19,000
250	4	NU314	11,000	9,000
	6		16,000	13,000
	8		20,000	19,000
280	4	NU316	9,000	7,000
	6		14,000	12,000
	8		19,000	17,000
315	4	NU319	7,000	5,000
	6		12,000	9,000
	8		17,000	15,000
355	4	NU322	5,000	4,000
	6		9,000	7,000
	8		14,000	13,000

Table 18 - Lubrication intervals for roller bearings at 70°C

Note 1 - This bearing must not operate in 2 pole motors at 60 Hz speed
 2 - Halve lubrication interval for vertical mounting
 3 - Halve lubrication interval for each 15°C above 70°C

Bearing monitoring

Optionally, bearing temperature detectors can be installed for condition monitoring. The most commonly used is the PT-100 (RTD), which is recommended for critical applications, for temperature affects re-greasing intervals and bearing life.

6. Mounting



Figure 21 - Mounting

The mounting configuration complies with IEC 60034-7. Standard mountings and their variations are shown in figure 22. A number code is used to define the mounting and terminal box position. The terminal box position is defined as viewed from the motor drive end shaft.

- B3R Terminal box on right side of the frame viewing the motor from D.E.
- B3L Terminal box on left side of the frame viewing motor from D.E.
- B3T Terminal box on top of the frame.

Standard Mounting Configurations

Foot Mount

B3 (IM1001) V5 (IM1011) V6 (IM1031) B6 (IM1051) B7 (IM1061) B8 (IM1071)

**Flange Mount
FF Flange**

B5 (IM3001) V1 (IM3011) V3 (IM3031)

**Foot & Flange Mount
FF Flange**

B35 (IM2001) V15 (IM2011) V36 (IM2031)

**Flange Mount
FC (NEMA) & C-DIN Flange**

B14 (IM3601) V18 (IM3611) V19 (IM3631)

**Foot & Flange Mount
FC (NEMA) & C-DIN Flange**

B34 (IM2101) IM2111 IM2131

Figure 22 - Mountings

Important:

1. Mountings IM B34 and IM B14 (with C flange) in frames 160 to 355M/L comply with NEMA MG1 Part 4 dimensions.
2. For vertically shaft down mounted motors, a canopy (rainhood) is recommended to prevent ingress of water and small objects into the fan cover (refer section 20).

As WEG motors are manufactured with high density cast iron and designed to provide the highest mechanical strength, they can be mounted in all possible configurations. **Every low voltage, off the shelf WEG W22 motor from 63 to 355M/L frame can be mounted in any position, horizontal or vertical**, providing the maximum axial and radial thrusts, as stated in WEG’s catalogues, are not exceeded.

Benefits: Reduces inventory costs, increases motor life expectancy

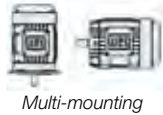

7. Terminal Box/Terminal Block

7.1 Main terminal box

The main terminal box of W22 motors is IP66 and made of FC-200 cast iron. It is diagonally split for easier handling of leads and connections.

For frame sizes IEC 225S/M to 355M/L the terminal box is displaced forward on the frame. This design allows improvement of air flow through the fins in addition to reducing operating temperatures. For this range of frames, the motor leads come out on the top of the frame. A side mounted terminal box position is achieved with the addition of an adapting device, supplied as standard for side mounted box motors (see figure 23).



Figure 23 - Terminal box mounted on the left side viewing from shaft end

In frames 225 to 355, the terminal box can be changed from the left to right and vice-versa just by changing the position of the adapting plate. Removing the adapting plate and adjusting the leads length, the terminal box can be mounted on top of the frame (B3T), as shown in figure 24. This procedure allows change of the terminal box position without disassembling the motor, resulting in a major reduction of inventory holdings and the time required to get the desired mounting.

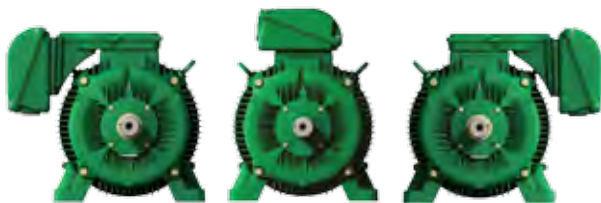

Figure 24 - Terminal box mounted on both sides and on top (frames 225 to 355)

Factory-supplied motors fitted with terminal box on top can be modified to left or right mounted terminal box. To do that, a specific kit consisting of an adapting device and connection leads must be ordered. Contact the WEG office closest to you for more information.

The terminal box can be rotated at 90° intervals. W22 mining motors in frames IEC 225S/M to 355M/L are supplied with cast iron removable gland plate. As an optional feature, the removable base can be supplied undrilled.

For frame sizes 63 to 200 the terminal box position is centralized on the motor frame and can be supplied in two configurations – left / right side (standard) or top (optional). A motor with a side mounted terminal box (B3R or B3L) can have the terminal box position located on the opposite side through modification.

Different configurations are available on request.

Frame	Main terminal box cable entry holes
63	1 x M20 x 1.5
71	1 x M20 x 1.5
80	1 x M20 x 1.5
90	1 x M25 x 1.5
100	1 x M25 x 1.5
112	1 x M32 x 1.5
132	1 x M32 x 1.5
160	2 x M40 x 1.5
180	2 x M40 x 1.5
200	2 x M50 x 1.5
225S/M	2 x M50 x 1.5
250S/M	2 x M63 x 1.5
280S/M	2 x M63 x 1.5
315S/M	2 x M63 x 1.5
315L	2 x M63 x 1.5
355M/L	2 x M80 x 2.0

Table 19 - Cable entry dimensions

Cable entry holes for W22 motors are in accordance with table 19. Threaded plastic plugs are provided to prevent water ingress during transportation and storage.

In order to guarantee the degree of protection, the incoming power lead termination must comply with the same requirements of the degree of protection shown on the motor nameplate.

7.2 Main terminal block

Motor power connection leads are marked in accordance with IEC 60034-8 and are connected to a terminal block which is made of polyester-based resin BMC (Bulk Moulding Compound) reinforced with fiber glass (see figure 25). Motors fitted with three or six connection leads are connected to a six-pin terminal block, while motors with nine or twelve connection leads are connected to two six-pin terminal blocks.



Figure 25 - Six-pin terminal block

7.3 Accessories terminal block

Accessory leads are mounted on quick-connection terminals as shown in figure 26. They are mounted in either the main terminal box (W22 Industrial) or additional terminal box (standard in W22 mining frames 160 to 355).

The additional terminal box is pre-drilled with one M20 x 1.5 cable entry hole.



Figure 26 - Terminals for accessories connection

For frames 132 to 355, an optional dedicated space heaters terminal box can be provided as shown in figure 27.



Figure 27 - Two accessory terminal boxes attached to main terminal box

8. Degree of Protection / Sealing System / Painting

8.1 Degree of protection

In accordance to IEC 60034-5 standard, the degree of protection of a rotating electrical machine consists of the letters IP followed by two characteristic numerals with the following meaning:

- First characteristic numeral: referred to protection of people against live parts and contact with moving parts (other than smooth rotating shafts and the like) inside the enclosure and protection of the machine against ingress of solid and foreign objects.
- Second characteristic numeral: protection of machines against harmful effects due to ingress of water.

W22 motors are supplied with IP66 degree of protection in conformance with IEC 60034-5, which means:

- First characteristic numeral 6: dust-tight machine. The enclosure provides full protection against ingress of dust.
- Second characteristic numeral 6: machine protected against heavy seas. Water from heavy seas or water projected in powerful jets shall not enter the machine in harmful quantities.

8.2 Sealing system

W22 motors are supplied with oil seal or W3Seal® (160 to 355 in W22 mining), or WSeal® (225 to 355 frame in the Industrial range).

The patented WSeal® seal consists of a V-ring with double lip enclosed by a metallic cap (see figure 28). The W3Seal® comprises of a V-ring, taconite labyrinth and O-ring seal. This is the best ever conceived seal for harsh, dusty mining environments.



Figure 28 - WSeal®



Figure 29 - W3Seal® for Mining

Mechanical Seal for B3 Foot Mounted Motors			
Frames	63 - 132	160 - 200	225 - 355
W22 Industrial	Oil Seal	Oil Seal	WSeal®
W22 Mining	Oil Seal	W3Seal®	W3Seal®

Table 20 - Types of seal

8.3 Painting

W22 motors are supplied as standard with a painting plan 203A consisting of:

- Primer: one coat with 20 to 55 µm of alkyd primer;
- Finishing: one coat with 50 to 75 µm of alkyd synthetic enamel.

This painting plan is suitable for normal, protected or unprotected, industrial applications and environments containing SO₂ (sulfur dioxide). W22 Industrial standard colour is green, whilst W22 mining is electric orange. Other colours are available upon request.

Other painting plans are available even for the most aggressive environments, as per table 21.

Painting Plan	Description
202E	Primer: one coat with 20 to 55µm of alkyd oxide red Intermediate: one coat with 20 to 30µm of isocyanate epoxy paint Finishing: one coat with 100 to 140µm of epoxy paint N2628 Recommended for pulp and paper, mining and chemical industries
202P	Primer: one coat with 20 to 55µm of alkyd oxide red Intermediate: one coat with 20 to 30µm of isocyanate epoxy paint Finishing: one coat with 70 to 100µm of polyurethane paint N2677 Recommended for food processing industries
211E	Primer: one coat with 100 to 140µm of epoxy paint N2630 Finishing: one coat with 100 to 140µm of epoxy paint N2628 Recommended for applications in refineries and petrochemical industries
211P	Primer: one coat with 100 to 140µm of epoxy paint N2630 Finishing: one coat with 70 to 100µm of PU paint N2677 Recommended for applications in refineries and petrochemical industries
212E	Primer: one coat with 75 to 105µm of epoxy paint N1277 Intermediate: one coat with 100 to 140µm of epoxy paint N2630 Finishing: one coat with 100 to 140µm of epoxy paint N2628 Recommended for applications in pulp and paper, mining, chemical and petrochemical industries
212P	Primer: one coat with 75 to 105µm of epoxy paint N1277 Intermediate: one coat with 100 to 140µm of epoxy paint N2630 Finishing: one coat with 70 to 100µm of PU paint N2677 Recommended for applications in pulp and paper, mining, chemical and petrochemical industries

Table 21 - Painting plans

Tropicalized painting

An ambient with relative humidity up to 95% does not require additional protection, other than space heaters to avoid water condensation inside the motor. However, for applications with relative humidity above 95%, an epoxy paint is applied to the motor internal parts, known as tropicalized painting.

9. Voltage / Frequency

The WEG W22 Industrial range is designed based on a multi-voltage concept, ie. the motors are suitable to operate at a combination of voltages and frequencies as follows :

Up to 100 frame (inclusive)			From 112 to 355 frame		
Connection	50Hz	60Hz	Connection	50Hz	60Hz
Δ	220-240V	254-276V	Δ	380-415V	440-480V
Y	380-415V	440-480V	Y	660-720V	760-830V

The WEG W22 Mining range is designed for 415V (in Y up to 100 frame and in Δ from 112 and above).

WEG also manufactures motors from 110V up to 13,800V, available on request.

Voltage and frequency variations are classified as Zone A or Zone B as per IEC 60034-1 the combination, depicted below in figure 30.

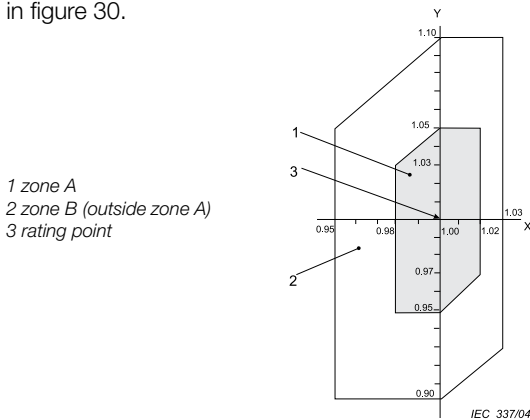

Figure 30 - Rated voltage and frequency variation limits for electric motors

IEC 60034-1 states an electric motor must be suitable to perform its main function (supply torque) continuously in Zone A. However, under this condition the motor may operate at a temperature rise above its rated value, due to power supply voltage and frequency variation.

The motor must also be suitable to perform its main function (supply torque) in Zone B, however significant performance changes will occur. Temperature rise will also be higher in Zone A than at rated voltage and frequency. Long term operation within Zone B is not recommended.

10. Overload Capacity

10.1 Constant overload

It is not unusual to see motors being overloaded for long periods of time. The most common causes are load and voltage fluctuations. To ensure trouble free operation, WEG W22 motors are designed with a 1.15 or higher service factor, hence with the capacity to cope with a 15% continuous overload when installed in a maximum ambient temperature of 40°C.

10.2 Momentary overload capacity of 150%

In the course of their lives, electric motors may be subject to momentary overloads. These can originate from voltage sags, load variations etc. If not properly selected, motors can stall or even fail prematurely. WEG motors are designed to withstand a momentary overload of 150% for up to 2 minutes (as per IEC 60034-1).

Benefits: Reliable operation, longer life

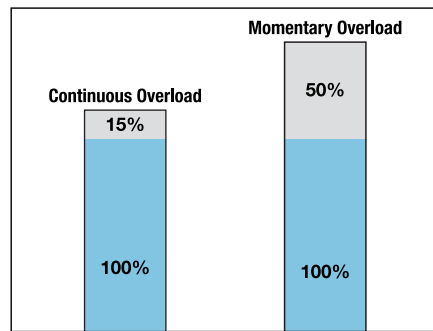

Figure 31 - WEG motor overload capacity

11. Ambient x Altitude

According to IEC 60034-1, the rated motor output power of an S1 duty motor is the continuous duty operation at the following ambient conditions (unless otherwise specified)

- With temperature varying between -20°C to +40°C
- With altitudes up to 1000 meters above sea level

For other temperature and altitude conditions the derating figures of table 22 must be applied in order to calculate the new maximum motor power (Pmax).

Electric motors are installed in many different environments, where the ambient temperature may vary widely, commonly from 5 to 40°C. The mining industry, however, sets forth a more demanding requirement; the suitability to operate at higher ambient temperatures, usually around 45 or 55°C.

The WEG W22 Mining motor are designed with low temperature rise, high temperature grease, low bearing temperature and high grade insulation, and hence are mechanically and electrically sound to operate at ambient temperatures of up to 55°C (at SF=1.0).

All low voltage motors are also guaranteed to operate down to -20°C and lower. Contact your local WEG office to confirm application demands and motor suitability.

T (°C)	Altitude (m)								
	1000	1500	2000	2500	3000	3500	4000	4500	5000
10							0.97	0.92	0.88
15						0.98	0.94	0.90	0.86
20					1.00	0.95	0.91	0.87	0.83
25				1.00	0.95	0.93	0.89	0.85	0.81
30			1.00	0.96	0.92	0.90	0.86	0.82	0.78
35		1.00	0.95	0.93	0.90	0.88	0.84	0.80	0.75
40	1.00	0.97	0.94	0.90	0.86	0.82	0.80	0.76	0.71
45	0.95	0.92	0.90	0.88	0.85	0.81	0.78	0.74	0.69
50	0.92	0.90	0.87	0.85	0.82	0.80	0.77	0.72	0.67
55	0.88	0.85	0.83	0.81	0.78	0.76	0.73	0.70	0.65
60	0.83	0.82	0.80	0.77	0.75	0.73	0.70	0.67	0.62
65	0.79	0.76	0.74	0.72	0.70	0.68	0.66	0.62	0.58
70	0.74	0.71	0.69	0.67	0.66	0.64	0.62	0.58	0.53
75	0.70	0.68	0.66	0.64	0.62	0.60	0.58	0.53	0.49
80	0.65	0.64	0.62	0.60	0.58	0.56	0.55	0.48	0.44

Table 21 - Correction factors for altitude and ambient temperature

12. WISE® Insulation System

12.1 Spike Resistant Wire

Spike-resistant wire is a new technology developed as a result of studies on the effect of modern IGBT drives on AC motors. The secret is in the enamelling process, which ensures superior insulation in order to protect all turns against rapid voltage rise times (dV/dt).

The industry has traditionally utilized 2 types of wire insulation: grade 2 (8 layers of standard enamel) and grade 3 (12 layers of standard enamel). This technology no longer meets the demands of modern drives, which created the need for advances in wire insulation. With the support of its chemical division, WEG has developed its own inverter rated enamel, resulting in the superior dielectric and mechanical properties of WEG’s insulation.

Benefits: Guaranteed performance with latest drives, reliability, longer life expectancy



Figure 32 - spike resistant wire

All W22 motors are supplied with WISE® (WEG insulation system evolution) insulation which includes spike-resistant enameled wire 200°C rated. The WISE® insulation system ensures long motor life when operated with variable frequency drive (see section 14).

The high voltage spikes and dV/dt generated by IGBT drives can reduce the life of a standard insulation by as much as 75%. Different to mains operation, where voltage surges may occur once in a while, VSD spikes can be impressed onto motor insulation thousands of times per second. A proper insulation system must be rated for use under continuous stress.

WEG’s WISE® insulation system is capable of withstanding voltage impulses of 1,600V peak and 5,200V/μs at a repetition rate of 5,000 times per second (5kHz), far superior to today’s industry standard. The WISE® insulation standard in all WEG W22 motors, is the result of WEG’s extensive research of the effects of drives on electric motors. No doubt the benefits of this superior insulation are also invaluable for applications where voltage surges are a concern. For more information consult our technical papers.

12.2 Class H

In addition to WEG’s unique spike resistant WISE® insulation, WEG motors use class H enamel and are impregnated with class H epoxy resin. The percentage of retained solids of a resin-based impregnation is on average 2 to 2.5 times better than that of varnish, the industry standard material. High voltage motors are VPI impregnated. For superior results with low voltage random-wound motors the continuous resin flow process is adopted.

Benefits: Higher corona inception voltage, better heat transfer, longer life

12.3 Temperature Rise

W22 motors are supplied with class H insulation with a temperature rise no higher than that of class B under normal operating conditions (unless otherwise specified).

The difference between the rated temperature of the class H insulation (125 K) and the motor full load temperature rise means that, in practice, W22 motors are suitable to operate at ratings (service factor) up to a limit where the temperature rise reaches the maximum value of their insulation class.

The ratio between temperature rise and service factor (SF) is given by the equation below:

$$\Delta T_{FINAL} \cong (SF)^2 \times \Delta T_{RATED KW}$$

W22 line SF may reach 1.25. This reserve of temperature also allows W22 motors with class B temperature rise (80 K) to operate continuously:

- Up to 25% above their rated output power, considering 40°C ambient temperature and 1000 m.a.s.l.
- Up to 55°C ambient temperature, maintaining the rated output power (standard for W22 mining)
- Up to 3000 m.a.s.l., keeping the rated output power

Bearing lubrication interval will change at different application conditions. Contact WEG for more information.

13. Motor Protection

Electric motor thermal protection can be classified as follows:

- Based on temperature
- Based on current
- Against condensation

13.1 Space heaters

The use of space heaters is recommended in two situations:

- Motors installed in environments with relative air humidity up to 95% in which the motor may remain idle for periods greater than 24 hours;
- Motors installed in environments with relative air humidity greater than 95%, regardless of the operating duty. It should be highlighted that in this situation it is strongly recommended that an epoxy paint, known as tropicalized painting, is applied in the internal components of the motor. More information can be obtained in section 8.3.

The supply voltage for space heaters must be specified on the purchase order. For all frame sizes, W22 motors can be provided with space heaters suitable for 110-127 V, 220-240 V and 380-480 V. As an option, dual voltage heaters of 110-127 / 220-240 V can be supplied for motor frame sizes 112 to 355.

The power rating and number of space heaters fitted depend on the size of the motor as indicated in table 23 below:

Frame	Power rating (W)
63 to 80	7.5
90 and 100	11
112	22
132 and 160	30
180 and 200	38
225 and 250	56
280 and 315	140
355	174

Table 23 - Power rating of space heaters

Heaters (240V) are standard for W22 Mining in frames 225 to 355.

13.2 Protection based on operating temperature

Continuous duty motors must be protected from overloads by a device embedded into the motor insulation or an independent protection system (usually a thermal overload relay with setting equal to or below the value obtained when multiplying the motor service factor by its rated current (In) as per table 24).

Service factor	Relay setting current
1.0 up to 1.15	In x SF
≥ 1.15	(In x SF) – 5%

Table 24 - Suggested relay setting current

PT-100 (RTD's)



Figure 33 - PT-100 (RTD)

These are temperature detectors (usually made of platinum, nickel or copper) with operating principle based on variation of their electrical resistance with temperature. These calibrated resistances vary linearly with temperature, allowing continuous monitoring of motor heating process through an RTD relay with high precision rate and response sensitivity.

The same detector can be used for alarm (with operation above the regular operating temperature) and trip (usually set to the maximum temperature of the insulation class).

	Recommended Settings	
	Alarm	Trip
Winding	155°C	180°C
Bearing	90°C	110°C

Table 25 - Recommended thermal protection settings for W22 range.

Thermistor (PTC)



Figure 34 - Thermistor (PTC)

These are semi-conductor type thermal protectors with hyperbolic resistance variation when its set temperature is reached. This abrupt resistance increase blocks the PTC current, making the PTC relay operate, tripping the motor circuit breaker.

Thermistors are of small dimensions, do not wear out and have quicker response time if compared to other thermal protectors. They do not, however, allow continuous motor temperature monitoring.

Together with their relays, thermistors and RTD's provide full protection against overheating caused by single phasing, overload, under or over-voltage or frequent reversing operations.

WEG RPW - PTCE05 is an electronic relay intended to interface with PTC signals. For more information refer to our website www.weg.net/au.

Bimetallic thermal protectors

These are silver-contact thermal sensors, normally closed, that operate at a certain temperature. When their temperature decreases below set point, they return to the original shape, allowing the silver contact to close again.

Bimetallic thermal protectors are series-connected with the main contactor coil, and they can be used either as alarm or trip.

There are also other types of thermal protectors such as PT-1000, KTY and thermocouples. Please contact WEG for more information.

Complete, simple to use, electronic motor protection can be achieved by using WEG smart relay.



Figure 35 - Smart relay

13.3 Protection based on operating current

Motor overload results in gradual temperature increase, to which RTD's, PTC's and bimetallic sensors offer suitable protection. However, to protect motors against short-circuit and locked rotor currents fuses must be used. This type of protection is highly effective for locked rotor conditions. Alternatively electro-magnetic motor protection circuit breakers (MPCB's) can be used.

WEG has a range of fuses to protect your electric motor, as well as MPCB's (see figure 36).



Figure 36 - MPCB's to 100A

14. Applications with Variable Frequency Drives

14.1 Consideration regarding rated voltage

W22 motors are built with WEG's patented WISE® insulation system (WEG Insulation System Evolution) – which ensures superior electrical insulation.

The stator winding is designed and tested to withstand the voltage impulse and transients inherent to VSD's. Different grades of insulation are used according to motor rated voltage and inverter-generated dV/dt. Refer to details in table 26.

Motor rated voltage	Peak voltage on motor terminals	dV/dt on motor terminals	Rise time	Time between pulses
	(phase to phase)	(phase to phase)		
Vn ≤ 460 V	≤ 1600 V	≤ 5200 V/μs	≥ 0.1 μs	≥ 6 μs

Table 26 - For VSD applications within above limits, no additional filters are required

Notes:

- 1 – To minimise insulation stress it is recommended the switching frequency is set to 5 kHz or below.
- 2 – If the above conditions are met (including the switching frequency) there is no need for filters on VSD output.

14.2 Torque restrictions on variable frequency drive applications

When driving constant torque loads, self-ventilated variable frequency driven motors have their torque limited at sub-rated frequency due to ventilation reduction. The following derating must be applied (refer to figure 37 and IEC 60034-17).

Constant torque condition

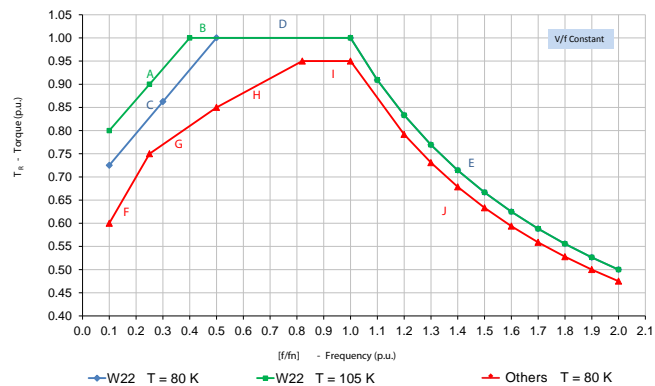

Figure 37 - Derating curve for constant torque applications - W22 E3 motors (blue and green curves) and non-WEG E2 motors (red curve) in accordance with IEC 60034-17.

Derating to limit temperature rise to maximum temperature of insulation system applicable to W22 motors (Green Curve)*		
Interval	Limited by	Apply this equation
A	$0.10 \leq f/f_n < 0.40$	$T_R = 0.6667 (f/f_n) + 0.7333$
B	$0.40 \leq f/f_n < 1.0$	$T_R = 1.0$
E	$f/f_n > 1.0$	$T_R = 1/(f/f_n) = f_n/f$

Derating to keep temperature rise equal to mains operation applicable to W22 motors (Blue Curve)**		
Interval	Limited by	Apply this equation
C	$0.10 \leq f/f_n < 0.50$	$T_R = 0.6875 (f/f_n) + 0.6563$
D	$0.50 \leq f/f_n < 1.0$	$T_R = 1.0$
E	$f/f_n > 1.0$	$T_R = 1/(f/f_n) = f_n/f$

Derating to keep temperature rise equal to mains operation applicable to other motors (Red Curve)**		
Interval	Limited by	Apply this equation
F	$0.10 \leq f/f_n < 0.25$	$T_R = (f/f_n) + 0.50$
G	$0.25 \leq f/f_n < 0.50$	$T_R = 0.40(f/f_n) + 0.65$
H	$0.50 \leq f/f_n < 0.83$	$T_R = 0.30(f/f_n) + 0.70$
I	$0.83 \leq f/f_n \leq 1.0$	$T_R = 0.95$
J	$f/f_n > 1.0$	$T_R = 0.95 / (f/f_n)$

Table 27 - Torque derating for constant torque operation below rated speed

(*) When the top green curve is applied the motor temperature rise will be limited by the temperature class of its insulation material. For example, for class F motors, the temperature rise will be limited at 105 K. This curve can only be used for class F insulation and class B temperature rise W22 motors in order to ensure that, when driven by frequency drive, the temperature rise remains within class F limits (below 105 K rise).

(**) When the lower blue curve is applied the motor temperature rise in a variable frequency drive will be the same as when driven by sinusoidal supply. In other words, class F insulation motors with class B temperature rise will remain with class B temperature rise (≤ 80 K) even when driven by variable frequency drives, which increases motor losses due to harmonics. This curve only applies to W22 motors.

14.3 Optimal Flux®

What is Optimal Flux®

Combining a WEG Variable Frequency Drive (VFD) with a WEG Motor results in Optimal Flux (patented).

The Optimal Flux control algorithm increases motor flux at low speeds, thereby allowing the same torque to be developed with lower current. The results are optimal motor flux at low speeds to produce full torque while minimising motor losses.

Why Optimal Flux® was developed

The air flow (cooling) from the shaft mounted fan used on a TEFC motor is dramatically reduced as speed decreases. If the load remains constant, as speed decreases the reduced cooling will result in motor overheating. Variable torque loads (centrifugal fans and pumps) require significantly less torque as speed decreases, however most other equipment is of the constant torque type.

WEG developed Optimal Flux (patented) to specifically address the needs of the broader constant torque (CT) VSD market. Specially those applications with +/-0.5% speed regulation without an encoder and a speed range greater than 10:1. Optimal Flux (patented) allows the operation of WEG W22 motors from a speed range approaching 5Hz upwards, without thermal damage, without the need for speed feedback from a shaft mounted encoder, without derating or the fitting of forced ventilation.

How does Optimal Flux® achieve lower motor losses

In an electric motor, most of the heat is the result of I²R losses. If motor current can be reduced even slightly, the resultant losses will be significantly reduced.

Constant torque loads require full torque at low speeds. Merely reducing the current would reduce both losses and torque, which would be unacceptable. The design characteristics of WEG W22 motors are loaded into the CFW09/CFW11 VFDs which allows the Optimal Flux (patented) control algorithm to adjust motor flux at low speeds thereby allowing the same torque to be developed at lower current. For more information consult our technical papers.



14.4 Torque derating with Optimal Flux®

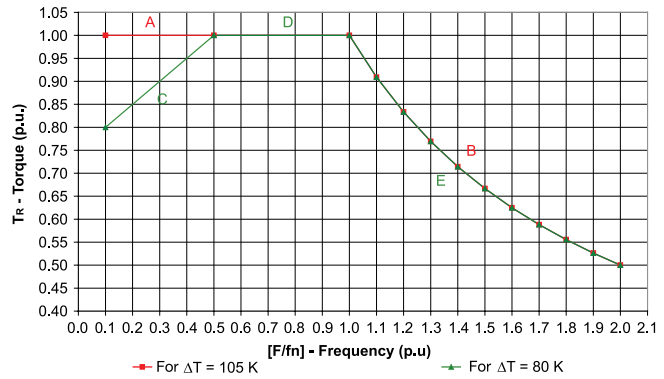

Figure 38 - Derating curve with Optimal Flux®

Derating for max. temperature rise with Optimal Flux®		
Interval	Limited by	Apply this equation
A	$0.10 \leq f/fn \leq 1.0$	$T_R = 1.0$ (constant torque)
B	$f/fn > 1.0$	$T_R = 1/(f/fn) = fn/f$

Derating to maintain rated temperature rise using Optimal Flux®		
Interval	Limited by	Apply this equation
C	$0.10 \leq f/fn < 0.50$	$T_R = 0.5(f/fn) + 0.75$
D	$0.50 \leq f/fn \leq 1.0$	$T_R = 1.0$ (constant torque)
E	$f/fn > 1.0$	$T_R = 1/(f/fn) = fn/f$

Table 28 - Equation for torque determination available with WEG patented Optimal Flux® applicable to W22 IEC Motor Series (TEFC Only)

14.5 Bearing currents

Common mode voltage, high dV/dt and high speed switching frequencies, inherent to any PWM drive, can generate shaft currents which circulate or discharge through the motor bearings. This electric current may also circulate through the driven load bearings. Left unchecked, the motor and/or driven equipment bearings may fail prematurely. There are three distinct mechanisms which may result in these destructive bearing currents, each requires specific mitigation measures.

This phenomenon is more noticeable in larger frame sizes (315 and above), and is less likely to occur in small motors. IEC 60034-17 recommends special bearing protection devices for motors of frame size 315 and above. Other entities, e.g. CSA and GAMBICA, suggest similar measures from frame 280. WEG offers the use of an insulated bearing housing and shaft grounding brush, as well as proper Motor and Variable Speed Drive earthing recommendations, which effectively prevents PWM drive-induced bearing damage. When VSD use is specified by the customer, these additional protective devices are supplied as standard from 280 frame.

In all cases it is essential that the user adheres to the motor and VSD supplier's recommendations, especially with regards to installation, cabling and grounding. For a comprehensive guide, please refer to the WEG Technical Guide - Induction motors fed by PWM frequency converters, available from all WEG offices.

The use of an insulated bearing housing rather than insulated bearing provides many advantages such as the ability to use standard bearings throughout the motor life. This significantly decreases maintenance and logistic costs.

14.6 Forced ventilation kit

For those cases where independent cooling system is required, e.g. use of non-WEG VSD's driving a motor below rated speed with a constant torque load, W22 motors can be supplied with forced ventilation kit, as shown in figure 39.

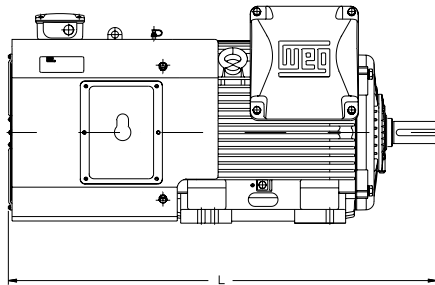

Figure 39 - Forced ventilation kit for W22 motors

When the forced ventilation kit is installed, the total motor length will be as shown in table 29.

Frame size	Poles	Total motor length (L) in mm	
		Without forced ventilation	With forced ventilation
90S	All	304	548
90L	All	329	573
100L	All	376	646
112M	All	393	660
132S	All	452	715
132M	All	490	753
160M	All	598	855
160L	All	642	899
180M	All	664	908
180L	All	702	946
200M	All	729	976
200L	All	767	1014
225S/M	2	856	1140
	4 to 8	886	1170
250S/M	2	965	1217
	4 to 8	965	1217
280S/M	2	1071	1348
	4 to 8	1071	1348
315S/M	2	1244	1459
	4 to 8	1274	1489
315 L	2	1353	1568
	4 to 8	1383	1598
355M/L	2	1412	1786
	4 to 8	1482	1856

Table 29 - Motor length with forced ventilation (mm)

14.7 Encoders

W22 motors can be supplied with encoders. Encoders can be fitted to motors with either forced ventilation or with shaft mounted cooling fan (TEFC). When encoders are fitted to TEFC machines, motors cannot have a second shaft end or be fitted with a raincover.

The following encoder models are available:

- Kübler - Model 5020 - 1024ppr (hollow shaft)
- Hengstler - RI58 - 1024ppr (hollow shaft)
- Line & Linde - XH861 - 1024ppr (hollow shaft)
- Hubner Berlin - HOG 10 - 1024ppr (hollow shaft)
- Hubner Guinzen - FGH4 - 1024ppr (shaft)

Other models can be supplied on request.

Note: The encoders described above are 1024 ppr. Models of 2048 pulses per revolution are available on request.

14.8 Minimum distance between fan cover and wall

Having the back of an electric motor facing against a wall can be detrimental to motor cooling, if a minimum distance between the fan cover and wall is not kept.

The minimum distance between a wall and motor fan cover is shown in table 30.

Frame	D (mm)
63 / 71 / 80	20
90 / 100 / 112	29
132 / 160	35
180	37
200	43
225 / 250	69
280 / 315 / 355	81

Table 30 - Minimum distance between motor fan cover and wall (mm)

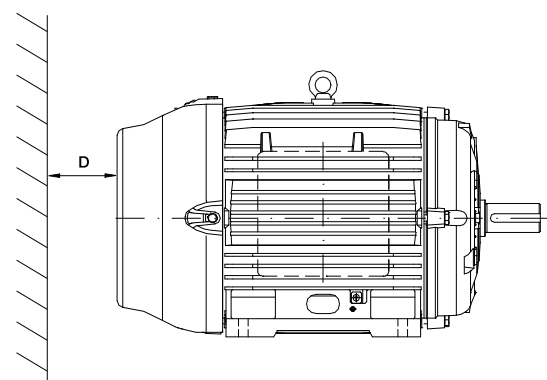

Figure 40 - Minimum distance to wall

15. W22 High Efficiency E3 Performance Data - 2 Pole

Part No.	Output kW	IEC Frame	Rated speed (rpm)	Full load current I _L (A)	Locked rotor current I _L /I _r	Full load torque T _L (Nm)	Locked rotor torque T _r /T _L	Break-down torque T _b /T _L	415 V						Sound pressure level dB (A)	Moment of Inertia J (kgm ²)	Max. locked rotor time(s)		Approx Weight (kg)
									% of full load								Cold	Hot	
									Efficiency η			Power factor (Cos φ)							
									50	75	100	50	75	100					
2 Pole - 3000 rpm - 50 Hz																			
K07 W22	0.18	63	2800	0.46	5.2	0.59	3.2	3.2	64.0	69.0	70.0	0.55	0.68	0.77	52	0.0002	70	32	6.7
K1 W22	0.25	63	2805	0.63	5.5	0.88	3.2	3.2	65.0	70.0	72.0	0.54	0.68	0.77	52	0.0002	59	27	7.2
K3 W22	0.37	71	2790	0.80	6.3	1.27	2.5	2.5	74.0	76.0	76.0	0.66	0.79	0.85	56	0.0004	26	12	7.5
K5 W22	0.55	71	2770	1.15	5.9	1.86	3.0	3.0	76.0	77.0	77.5	0.68	0.81	0.86	56	0.0005	40	18	8.5
K7 W22	0.75	80	2825	1.52	7.5	2.55	3.5	3.5	81.0	83.0	83.4	0.63	0.76	0.82	59	0.0008	62	28	13.5
K9 W22	1.1	80	2830	2.21	7.4	3.73	3.6	3.6	82.0	84.0	84.6	0.63	0.76	0.82	59	0.0009	51	23	15.0
K11 W22	1.5	90S	2875	2.91	7.6	5.00	3.3	3.3	84.0	86.0	86.5	0.64	0.76	0.83	62	0.0020	33	15	18.5
K15 W22	2.2	90L	2870	4.20	7.5	7.35	3.4	3.5	86.5	87.0	87.7	0.65	0.77	0.83	62	0.0026	26	12	23.5
K22 W22	3	100L	2910	5.47	8.5	9.81	3.4	3.4	86.5	87.8	88.7	0.69	0.81	0.86	67	0.0064	33	15	32.0
K192 W22	4	112M	2900	7.22	7.7	13.1	2.9	3.5	88.1	89.1	89.6	0.69	0.80	0.86	64	0.0080	48	22	41.0
K20 W22	5.5	132S	2935	9.73	8.0	17.9	2.7	2.9	88.9	90.4	90.5	0.72	0.82	0.87	67	0.0189	42	19	65.0
K24 W22	7.5	132S	2935	13.3	8.5	24.4	3.0	3.4	89.4	90.8	91.2	0.69	0.80	0.86	67	0.0252	37	17	69.0
K27 W22	9.2	132M	2930	15.9	8.5	30.0	2.9	3.3	90.7	91.5	91.5	0.75	0.84	0.88	67	0.0306	35	16	78.0
K29 W22	11	160M	2950	19.4	8.0	35.6	2.7	3.5	91.0	92.3	92.7	0.71	0.81	0.85	67	0.0554	37	17	115
K31 W22	15	160M	2950	26.1	8.0	48.5	2.6	3.3	91.5	92.5	92.9	0.71	0.81	0.86	67	0.0625	26	12	119
K33 W22	18.5	160L	2950	32.1	8.4	59.9	2.8	3.6	92.0	92.9	93.2	0.70	0.80	0.86	67	0.0735	18	8	136
K35 W22	22	180M	2950	37.4	8.6	71.2	2.7	3.3	92.8	93.8	94.0	0.76	0.84	0.87	70	0.1084	31	14	180
K37 W22	30	200L	2960	51.4	7.4	96.8	2.7	2.8	93.2	94.1	94.4	0.76	0.83	0.86	74	0.1865	68	31	245
K39 W22	37	200L	2965	63.2	7.3	119	2.6	2.9	93.3	94.0	94.6	0.73	0.82	0.86	69	0.2119	37	17	265
K41 W22	45	225S/M	2970	74.8	8.0	145	2.4	3.2	94.6	95.1	95.1	0.77	0.85	0.88	74	0.4415	26	12	416
K43 W22	55	250S/M	2965	90.1	7.9	178	2.8	2.9	94.9	95.3	95.4	0.80	0.86	0.89	74	0.4924	31	14	485
K45 W22	75	250S/M	2965	122	7.9	241	3.0	2.8	95.0	95.3	95.4	0.83	0.87	0.89	74	0.5132	24	11	500
K47 W22	90	280S/M	2980	146	7.4	288	2.2	2.8	94.8	95.6	95.8	0.84	0.89	0.90	77	1.3400	66	30	762
K49 W22	110	280S/M	2980	177	7.9	353	2.3	2.9	94.8	95.7	96.0	0.82	0.88	0.90	77	1.5600	46	21	819
K61 W22	132	315S/M	2980	212	7.5	423	2.1	2.8	95.2	95.9	96.3	0.83	0.89	0.90	77	2.5600	66	30	1048
K51 W22	150	315S/M	2980	241	7.5	481	2.4	2.8	95.3	96.0	96.4	0.84	0.88	0.90	77	2.8300	70	32	1070
K162 W22	160	315S/M	2980	253	7.9	513	2.3	2.8	95.6	96.2	96.6	0.83	0.89	0.91	77	2.9900	53	24	1129
K53 W22	185	315S/M	2980	296	7.8	593	2.4	2.7	95.7	96.4	96.6	0.83	0.89	0.90	77	3.2000	48	22	1197
K202 W22	200	315S/M	2980	320	8.2	641	2.6	2.8	96.0	96.5	96.7	0.83	0.89	0.90	77	3.4200	37	17	1305
K55 W22	220	355M/L	2985	352	7.7	704	2.0	2.7	95.8	96.5	96.7	0.85	0.88	0.90	80	4.6100	48	22	1585
K57 W22	250	355M/L	2985	395	7.7	800	2.1	2.8	96.0	96.7	96.8	0.86	0.90	0.91	80	5.0400	48	22	1665
K59 W22	300	355M/L	2985	474	8.2	960	2.4	2.9	95.0	95.7	95.8	0.84	0.91	0.92	80	6.01	68	31	1838
High-Output Design - Special Frame																			
K20/1 W22	5.5	112M*	2895	10.0	8.0	18.1	3.0	3.4	88.0	88.6	88.6	0.70	0.81	0.86	64	0.0095	31	14	43
K29/1 W22	11	132M*	2925	18.9	8.2	35.9	2.7	3.0	90.8	91.2	91.2	0.75	0.85	0.89	67	0.0306	24	11	78
K55/1 W22	220	315L	2980	348	7.7	704	2.4	2.6	96.1	96.5	96.7	0.84	0.89	0.91	78.0	3.72	53	24	1370
K57/1 W22	250	315L	2980	395	7.8	800	2.5	2.7	96.4	96.6	96.8	0.86	0.90	0.91	78.0	4.17	37	17	1434

Mounting Configurations and order codes

Refer to page 27 for mounting configuration and details of order codes.

Other kW/frame combinations available on request. Please consult your nearest WEG office for details.

Notes:

- 1) The values shown are subject to change without prior notice.
- 2) To obtain actual values prior to order placement contact your nearest WEG office.
- 3) Efficiency test method B as per AS/NZS 1359.5-2004.
- 3) Noise level is mean sound pressure at 1 meter as per AS 60034.9 standard.

* Output available in reduced frame; meeting efficiency level E2.

15. W22 High Efficiency E3 Performance Data - 4 Pole

Part No.	Output kW	IEC Frame	Rated speed (rpm)	Full load current I _r (A)	Locked rotor current I _L /I _r	Full load torque T _r (Nm)	Locked rotor torque T _L /T _r	Break-down torque T _v /T _r	415 V						Sound pressure level dB (A)	Moment of Inertia J (kgm ²)	Max. locked rotor time(s)		Approx Weight (kg)
									% of full load								Cold	Hot	
									Efficiency η			Power factor (Cos φ)							
									50	75	100	50	75	100					
4 Pole - 1500 rpm - 50 Hz																			
K08 W22	0.18	63	1400	0.55	4.6	1.27	2.4	2.5	58.0	64.0	67.5	0.46	0.57	0.68	44	0.0006	59	27	7.2
K2 W22	0.25	71	1370	0.65	4.8	1.77	2.1	2.3	69.0	71.0	72.5	0.52	0.65	0.74	43	0.0007	143	65	8.0
K4 W22	0.37	71	1370	0.93	4.8	2.55	2.6	2.6	71.0	74.0	75.5	0.51	0.64	0.73	43	0.0008	123	56	9.5
K6 W22	0.55	80	1420	1.20	6.3	3.73	2.9	3.2	77.0	79.0	80.0	0.61	0.74	0.80	44	0.0026	48	22	12.5
K8/1 W22	0.75	90S	1455	1.54	7.8	4.90	2.4	3.3	82.5	84.0	84.5	0.60	0.73	0.80	49	0.0049	46	21	18.5
K10 W22	1.1	L90S	1460	2.23	8.2	7.16	2.7	3.1	85.0	85.9	85.9	0.62	0.74	0.80	49	0.0063	26	12	23.0
K12 W22	1.5	L90L	1455	3.07	7.9	9.81	2.8	3.4	85.0	86.5	87.1	0.56	0.70	0.78	49	0.0071	29	13	24.0
K16 W22	2.2	L100L	1440	4.33	8.1	14.6	3.9	3.6	87.2	88.2	88.5	0.60	0.73	0.80	53	0.0108	42	19	35.0
K23 W22	3	L100L	1440	5.85	7.5	19.9	3.5	3.3	87.5	88.5	89.1	0.60	0.73	0.80	53	0.0120	37	17	37.5
K194 W22	4	112M	1450	7.62	7.0	26.4	2.3	3.1	88.8	89.9	90.1	0.62	0.74	0.81	56	0.0182	33	15	44.0
K21 W22	5.5	132S	1465	9.93	8.2	35.9	2.4	3.4	90.0	90.7	91.0	0.67	0.79	0.85	56	0.0528	35	16	69.0
K25 W22	7.5	132M	1465	13.4	8.2	48.9	2.5	3.4	91.0	91.5	91.6	0.69	0.80	0.85	56	0.0642	29	13	78.0
K30 W22	11	160M	1470	20.0	7.0	71.5	2.5	3.0	91.0	91.8	92.2	0.65	0.76	0.83	61	0.1397	37	17	123
K32 W22	15	160L	1470	27.4	7.3	97.5	2.7	3.2	91.8	92.5	93.0	0.65	0.76	0.82	61	0.1743	22	10	145
K34 W22	18.5	180M	1470	33.5	8.0	121	2.9	2.9	91.7	93.1	93.5	0.65	0.76	0.82	64	0.1914	26	12	175
K36 W22	22	180L	1475	38.0	7.9	142	2.8	2.9	92.5	93.5	93.7	0.71	0.81	0.86	64	0.2272	35	16	195
K38 W22	30	200L	1480	54.1	7.3	193	2.5	3.0	92.8	93.6	94.2	0.64	0.75	0.82	63	0.3469	35	16	243
K40/1 W22	37	225S/M	1480	63.2	7.8	239	2.7	3.0	94.0	94.6	94.6	0.72	0.81	0.86	63	0.6388	31	14	392
K42 W22	45	225S/M	1480	76.5	7.9	290	2.8	3.2	94.2	94.8	94.8	0.70	0.80	0.85	63	0.6903	29	13	420
K44 W22	55	250S/M	1480	93.4	7.9	355	2.8	3.3	94.6	95.0	95.3	0.71	0.81	0.86	64	1.1100	31	14	507
K46 W22	75	250S/M	1480	125	8.4	484	2.8	3.3	95.0	95.5	95.5	0.73	0.83	0.87	64	1.2200	18	8	531
K48 W22	90	280S/M	1485	152	7.4	579	2.3	2.8	95.0	95.5	95.8	0.74	0.82	0.86	69	2.5500	55	25	777
K50 W22	110	280S/M	1485	183	7.6	708	2.4	2.8	95.4	95.8	96.0	0.74	0.83	0.87	69	3.2500	53	24	884
K62 W22	132	315S/M	1490	222	7.6	846	2.9	3.0	95.5	96.0	96.4	0.75	0.83	0.86	71	4.2200	57	26	1095
K52 W22	150	315S/M	1490	252	7.0	962	2.5	2.5	95.5	96.3	96.4	0.76	0.84	0.86	71	4.4200	57	26	1110
K164 W22	160	315S/M	1490	265	7.6	1030	2.6	2.6	95.7	96.2	96.5	0.75	0.83	0.87	71	4.6500	48	22	1152
K54 W22	185	315S/M	1490	307	7.6	1187	2.5	2.5	95.8	96.3	96.5	0.74	0.83	0.87	71	4.9700	40	18	1222
K204 W22	200	315S/M	1490	331	7.6	1285	2.5	2.5	96.1	96.5	96.7	0.74	0.83	0.87	71	5.3000	44	20	1332
K56 W22	220	355M/L	1490	372	7.4	1412	2.4	2.5	96.0	96.6	96.8	0.72	0.80	0.85	74	7.5200	44	20	1554
K58 W22	250	355M/L	1490	422	7.3	1598	2.3	2.4	96.2	96.6	96.9	0.73	0.82	0.85	74	8.5900	35	16	1621
K60 W22	300	355M/L	1490	501	7.3	1922	2.3	2.5	96.4	96.7	96.9	0.74	0.83	0.86	74	10.4000	44	20	1815
K3554 W22	355	355M/L	1490	593	7.2	2275	2.4	2.5	96.5	96.8	96.9	0.74	0.83	0.86	74	11.6000	33	15	1878
High-Output Design - Special Frame																			
K8 W22	0.75	L80*	1420	1.53	6.8	5.00	2.6	2.6	81.0	82.5	83.2	0.62	0.75	0.82	44	0.0037	42	19	15.5
K28 W22	9.2	132M/L*	1465	16.8	8.3	60.0	2.8	3.5	90.3	91.0	91.0	0.66	0.78	0.84	56	0.0681	22	10	82.0
K40 W22	37	200L	1480	66.4	7.0	239	2.6	3.0	93.3	94.0	94.5	0.64	0.76	0.82	63	0.3994	31	14	284
K56/1 W22	220	315L	1490	368	7.8	1412	2.6	2.6	96.1	96.6	96.7	0.74	0.83	0.86	73.0	6.86	35	16	1430
K58/1 W22	250	315L	1490	417	8.0	1598	2.7	2.6	96.2	96.6	96.9	0.73	0.82	0.86	73.0	8.39	35	16	1527

Mounting Configurations and order codes
Refer to page 27 for mounting configuration and details of order codes.
Other kW/frame combinations available on request.
Please consult your nearest WEG office for details.

Notes:

- 1) The values shown are subject to change without prior notice. To obtain actual values prior to order placement contact your nearest WEG office.
- 2) Efficiency test method B as per AS/NZS 1359.5-2004.
- 3) Noise level is mean sound pressure at 1 meter as per AS 60034.9 standard.

* Output available in reduced frame; meeting efficiency level E2.

15. W22 High Efficiency E3 Performance Data - 6 Pole

Part No.	Output kW	IEC Frame	Rated speed (rpm)	Full load current I _L (A)	Locked rotor current I _L /I _r	Full load torque T _L (Nm)	Locked rotor torque T _r /T _L	Break-down torque T _v /T _L	415 V						Sound pressure level dB (A)	Moment of Inertia J (kgm ²)	Max. locked rotor time(s)		Approx Weight (kg)
									% of full load								Cold	Hot	
									Efficiency η			Power factor (Cos φ)							
									50	75	100	50	75	100					
6 Pole - 1000 rpm - 50 Hz																			
K08A W22	0.18	71	900	0.64	3.2	1.87	2	2.1	58	64	65	0.4	0.51	0.6	43	0.0008	260	118	11.5
K2A W22	0.25	71	880	0.87	3.2	2.75	2	2	58	62.8	63.8	0.39	0.51	0.6	43	0.0008	196	89	11.5
K4A W22	0.37	80	925	1.05	4.7	3.82	2.1	2.2	62	67.5	70	0.48	0.61	0.7	43	0.0024	31	14	12.5
K6A W22	0.55	80	925	1.4	4.8	5.69	2.2	2.2	68	72.5	73	0.5	0.64	0.75	43	0.0034	44	20	14.5
K8A W22	0.75	L90S	945	1.82	5.2	7.55	2.5	2.8	78	80.1	80.6	0.5	0.62	0.71	45	0.0066	68	31	22
K10A/1 W22	1.1	100L	705	3.1	4.6	14.9	2.1	2.4	75	79	79.6	0.41	0.53	0.62	50	0.0143	79	36	33
K12A W22	1.5	100L	950	3.5	5.5	15.1	2.3	2.8	82	83	84.1	0.49	0.62	0.71	44	0.0143	66	30	32
K16A W22	2.2	112M	950	4.96	6	22.2	2.5	2.6	84	85.5	85.6	0.53	0.64	0.72	48	0.0257	57	26	42
K23A W22	3	132S	960	6.56	6.4	29.8	2	2.3	86	87	87.1	0.52	0.65	0.73	52	0.0453	84	38	61
K196 W22	4	132M	960	8.55	6.5	39.8	2.2	2.5	87	88	88	0.53	0.66	0.74	52	0.0566	70	32	66
K21A W22	5.5	132M/L	965	12	7	54.4	2.5	2.8	87.5	88.5	89.1	0.5	0.64	0.72	52	0.0755	57	26	80
K25A W22	7.5	160M	975	14.2	6.5	73.5	2.3	2.9	89.3	90.3	90.7	0.63	0.74	0.81	56	0.1492	44	20	122
K28A W22	9.2	160L	975	17.3	6.5	90.4	2.3	2.9	90.0	90.6	91.0	0.64	0.75	0.81	56	0.1756	40	18	137
K30A W22	11	160L	975	20.7	6.5	108	2.4	3	90	90.8	91.2	0.62	0.74	0.81	56	0.2111	35	16	143
K32A W22	15	180L	975	27	8	147	2.6	3.2	91.3	91.7	92	0.65	0.78	0.84	56	0.324	22	10	193
K34A W22	18.5	200L	980	33.9	6.2	180	2.2	2.8	91.7	92.3	92.5	0.65	0.76	0.82	60	0.3861	42	19	223
K36A W22	22	200L	980	40.2	6.3	215	2.3	2.9	92	92.6	92.9	0.65	0.76	0.82	60	0.4563	40	18	240
K38A W22	30	225S/M	985	52.2	7.4	291	2.3	2.8	93.7	94	94	0.7	0.8	0.85	63	0.9559	37	17	401
K40A W22	37	250S/M	985	64.2	7.4	359	2.3	2.7	94	94.4	94.4	0.72	0.81	0.85	64	1.42	37	17	486
K42A W22	45	250S/M	990	77.9	8	434	2.8	2.8	93.5	94.5	94.5	0.7	0.8	0.85	64	1.61	22	10	550
K44A W22	55	280S/M	990	98.3	6.7	531	2.2	2.7	94.5	95	95.3	0.67	0.77	0.82	65	3.25	62	28	723
K46A W22	75	280S/M	990	137	8	724	3	3.5	94.8	95.3	95.5	0.63	0.75	0.8	65	4.48	18	8	725
K48A W22	90	315S/M	990	157	6.7	869	2.2	2.5	95.3	95.8	96.1	0.67	0.78	0.83	67	6.51	75	34	1048
K50A W22	110	315S/M	990	192	6.8	1059	2.4	2.6	95.5	96	96.2	0.67	0.78	0.83	67	7.23	70	32	1106
K62A W22	132	315S/M	990	232	7.2	1275	2.5	2.7	95.6	96.1	96.3	0.67	0.77	0.82	67	8.32	57	26	1190
K52A W22	150	315S/M	990	261	7.5	1451	2.5	2.7	95.8	96.3	96.3	0.69	0.79	0.83	67	8.9	44	20	1365
K166 W22	160	355M/L	990	294	6.5	1544	2.1	2.3	94.9	95.6	95.8	0.63	0.74	0.79	73	10.2	73	33	1594
K54A W22	185	355M/L	990	340	6.6	1785	2.2	2.4	94.9	95.6	95.8	0.64	0.74	0.79	73	11.1	75	34	1666
K206 W22	200	355M/L	995	361	6.5	1927	2.1	2.3	95.4	96	96.2	0.64	0.75	0.8	73	12	88	40	1739
K56A W22	220	355M/L	995	397	6.5	2108	2.2	2.3	95.5	96.1	96.3	0.64	0.75	0.80	73	13.4	79	36	1854
K58A W22	250	355M/L	995	451	6.5	2403	2.3	2.4	95.5	96.1	96.3	0.64	0.75	0.8	73	15	84	38	1970
K60A W22	300	355M/L	995	548	6.4	2883	2.1	2.4	94.9	95.9	96.3	0.63	0.73	0.79	73	15	66	30	1970
High-Output Design - Special Frame																			
K10A W22	1.1	L90L*	920	2.70	5	112	2.2	2.2	72.0	77.7	79.9	0.48	0.61	0.71	45	0.0077	22	10	25
K166/1 W22	160	315L	990	279	7.4	1540	2.6	2.7	95.7	96.2	96.4	0.67	0.78	0.83	68	11.1	53	24	1448

Mounting Configurations and order codes

Refer to page 27 for mounting configuration and details of order codes.

Other kW/frame combinations available on request. Please consult your nearest WEG office for details.

Notes:

- 1) The values shown are subject to change without prior notice. To obtain actual values prior to order placement contact your nearest WEG office.
- 2) Efficiency test method B as per AS/NZS 1359.5-2004.
- 3) Noise level is mean sound pressure at 1 meter as per AS 60034.9 standard.

* Output available in reduced frame; meeting efficiency level E2.

15. W22 High Efficiency E3 Performance Data - 8 Pole

Part No.	Output kW	IEC Frame	Rated speed (rpm)	Full load current I _L (A)	Locked rotor current I _L /I _r	Full load torque T _L (Nm)	Locked rotor torque T _L /T _r	Break-down torque T _b /T _r	415 V						Sound pressure level dB (A)	Moment of Inertia J (kgm ²)	Max. locked rotor time(s)		Approx Weight (kg)
									% of full load								Cold	Hot	
									Efficiency η			Power factor (Cos φ)							
									50	75	100	50	75	100					
8 Pole - 750 rpm - 50 Hz																			
K08B W22	0.18	80	680	0.65	3.3	2.56	2.0	2.2	51.0	57.0	59.0	0.45	0.55	0.65	42	0.0029	139	63	13.5
K2B W22	0.25	80	680	0.88	3.3	3.54	2.0	2.2	53.0	58.0	60.0	0.45	0.56	0.66	42	0.0034	108	49	14.5
K4B W22	0.37	90S	690	1.26	3.7	5.11	2.1	2.4	61.0	66.0	66.0	0.41	0.53	0.62	43	0.0052	117	53	19.0
K6B W22	0.55	90L	685	1.72	3.6	7.65	1.8	2.1	63.0	66.5	66.5	0.44	0.57	0.67	43	0.0063	90	41	23.0
K8B W22	0.75	100L	710	2.19	4.6	10.1	1.9	2.3	74.0	77.0	77.0	0.41	0.53	0.62	50	0.0127	112	51	30.5
K10B W22	1.1	100L	705	3.10	4.6	14.9	2.1	2.4	75.0	79.0	79.6	0.41	0.53	0.62	50	0.0143	79	36	33.0
K12B W22	1.5	112M	705	3.78	5.0	20.3	2.5	2.8	79.0	80.5	81.2	0.45	0.59	0.68	46	0.0238	79	36	43.0
K16B W22	2.2	132S	710	5.09	6.2	29.6	2.3	2.5	82.8	83.0	83.6	0.51	0.65	0.72	48	0.0690	59	27	69.0
K23B W22	3	132M	710	6.80	6.4	40.4	2.4	2.6	84.1	84.9	85.2	0.51	0.64	0.72	48	0.0838	46	21	75.0
K198 W22	4	160M	725	8.93	5.0	52.7	2.1	2.3	85.0	86.8	86.6	0.52	0.65	0.72	51	0.1229	75	34	114
K21B W22	5.5	160M	725	12.0	5.0	72.5	2.1	2.3	86.0	87.3	87.7	0.52	0.65	0.73	51	0.1492	62	28	123
K25B W22	7.5	160L	730	16.1	5.3	98.1	2.2	2.5	87.0	88.3	88.9	0.52	0.65	0.73	51	0.2199	48	22	145
K28B W22	9.2	180M	725	17.4	6.0	121.9	2.0	2.6	89.0	89.3	89.6	0.63	0.75	0.82	51	0.2575	33	15	173
K30B W22	11	180L	725	22.3	6.5	145	2.3	2.7	89.5	90.0	90.3	0.55	0.68	0.76	51	0.2846	26	12	185
K32B W22	15	200L	730	30.8	4.9	196	1.9	2.1	90.0	91.0	91.4	0.56	0.68	0.74	56	0.4571	75	34	235
K34B W22	18.5	225S/M	735	34.3	6.5	240	1.7	2.5	93.0	93.0	92.7	0.63	0.75	0.81	56	0.8219	62	28	377
K36B W22	22	225S/M	735	40.7	6.5	286	1.8	2.5	93.0	93.1	93.0	0.63	0.75	0.81	56	0.9574	48	22	402
K38B W22	30	250S/M	735	54.0	7.4	390	1.9	2.8	93.3	93.3	93.2	0.66	0.77	0.83	56	1.4300	40	18	490
K40B/1 W22	37	280S/M	740	69.2	6.0	478	1.8	2.3	93.7	94.2	94.2	0.63	0.73	0.79	59	2.8200	70	32	673
K42B W22	45	280S/M	740	83.9	6.0	581	1.8	2.2	94.0	94.5	94.5	0.63	0.73	0.79	59	3.4900	66	30	741
K44B W22	55	280S/M	740	108	7.0	710	2.3	2.5	94.0	94.6	94.6	0.55	0.68	0.75	59	3.9400	40	18	830
K46B W22	75	315S/M	740	137	6.0	968	1.8	2.2	94.6	95.1	95.2	0.65	0.75	0.80	62	6.5600	88	40	1049
K48B W22	90	315S/M	740	164	6.0	1157	1.9	2.2	94.9	95.3	95.5	0.65	0.75	0.80	62	7.8400	88	40	1149
K50B W22	110	355M/L	745	202	6.2	1412	1.3	2.3	94.7	95.8	95.8	0.62	0.74	0.79	70	12.6000	123	56	1484
K62B W22	132	355M/L	745	242	6.2	1697	1.3	2.3	95.4	96.1	96.1	0.64	0.74	0.79	70	14.7000	106	48	1587
K52B W22	150	355M/L	745	275	6.8	1922	1.6	2.3	95.5	96.3	96.3	0.64	0.75	0.79	70	16.8000	110	50	1747
K168 W22	160	355M/L	745	289	6.4	2055	1.3	2.3	95.4	95.9	96.3	0.64	0.75	0.80	70	17.3	123	56	1747
K54B W22	185	355M/L	745	334	6.3	2373	1.3	2.3	95.5	95.9	96.3	0.64	0.75	0.80	70	18.9000	123	56	1819
K208 W22	200	355M/L	745	361	6.2	2566	1.3	2.3	95.5	95.9	96.3	0.65	0.76	0.80	70	19.8	123	56	1891
K56B W22	220	355M/L	745	409	8.0	2824	2.2	3.0	95.3	96.0	96.0	0.60	0.73	0.78	70	19.8000	123	56	1891
High-Output Design - Special Frame																			
K40B W22	37	250S/M*	735	68.0	8.0	481	2.2	3.0	93.3	93.5	93.5	0.63	0.75	0.81	56	1.6600	70	32	673

Mounting Configurations

Part numbers for alternative mounting configurations

W22 Industrial

K07 W22 = W22 E3 Industrial, B3 (Foot Mounted)

L07 W22 = W22 E3 Industrial, B35 (Foot & Flange Mounted)

M07 W22 = W22 E3 Industrial, B5 (Flange Mounted)

W22 Mining

KTE07 W22M = W22 E3 Mining, B3 (Foot Mounted)

LTE07 W22M = W22 E3 Mining, B35 (Foot & Flange Mounted)

MTE07 W22M = W22 E3 Mining, B5 (Flange Mounted)

Notes:

1) The values shown are subject to change without prior notice.

To obtain actual values prior to order placement contact your nearest WEG office.

2) Efficiency test method B as per AS/NZS 1359.5-2004.

3) Noise level is mean sound pressure at 1 meter as per AS 60034.9 standard.

* Output available in reduced frame; meeting efficiency level E2.

**Other kW/frame combinations available on request.
Please consult your nearest WEG office for details.**

16. W22 Mechanical data - frames 63 to 132

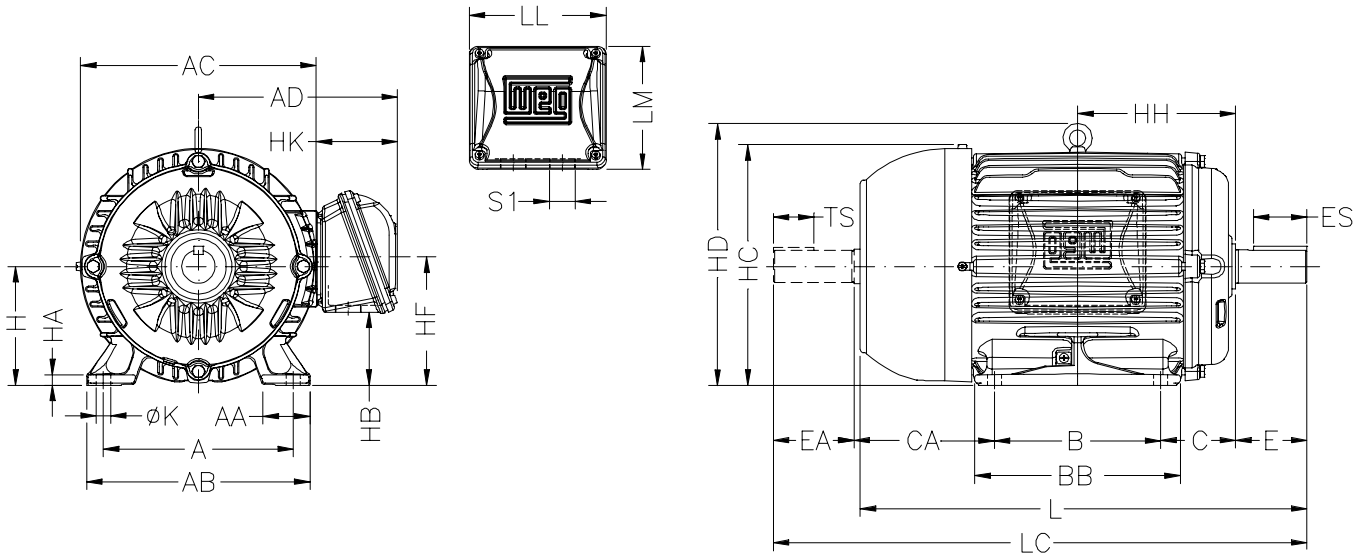

Main Dimensions (mm)																								Bearings		
IEC Frame	A	AA	AB	AC	AD	B	BA	BB	C	CA	H	HA	HB	HC	HD	HF	HH	HK	LL	LM	K	L	LC	S1	D.E.	N.D.E.
63	100	25.5	116	125	122	80	N/A	95	40	78	63	7	25.5	129	N/A	68.5	80	59	108	98	7	216	241	M20x1.5	6201 ZZ	6201 ZZ
71	112	28.5	132	141	130	90	N/A	113.5	45	88	71	7	33	145	N/A	76	90	59	108	98	7	248	276	M20x1.5	6202 ZZ	6202 ZZ
80	125	30.5	149	159	139	100	N/A	125.5	50	93	80	8	43.5	163	N/A	87	100	59	108	98	10	276	313	M20x1.5	6204 ZZ	6203 ZZ
L80	125	30.5	149	159	139	100	N/A	125.5	50	93	80	8	43.5	163	N/A	87	100	59	108	98	10	325	362	M20x1.5	6204 ZZ	6203 ZZ
90S	140	36.5	164	179	157	100	N/A	131	56	104	90	9	45	182	N/A	90	106	67	115	104	10	304	350	M20x1.5	6205 ZZ	6204 ZZ
L90S	140	36.5	164	179	157	100	N/A	131	56	104	90	9	45	182	N/A	90	106	67	115	104	10	355	381	M20x1.5	6205 ZZ	6204 ZZ
90L	140	36.5	164	179	157	125	N/A	156	56	104	90	9	45	182	N/A	90	118.5	67	115	104	10	329	375	M20x1.5	6205 ZZ	6204 ZZ
L90L	140	36.5	164	179	157	125	N/A	156	56	104	90	9	45	182	N/A	90	118.5	67	115	104	10	360	406	M20x1.5	6205 ZZ	6204 ZZ
100L	160	40	188	199	167	140	N/A	173	63	118	100	10	61.5	205	244	106.4	133	67	115	104	12	376	431	M20x1.5	6206 ZZ	6205 ZZ
L100L	160	40	188	199	167	140	N/A	173	63	118	100	10	61.5	205	244	106.4	133	67	115	104	12	420	475	M20x1.5	6206 ZZ	6205 ZZ
112M	190	40.5	220	222	192	140	N/A	177	70	128	112	10	54.5	235	280	112	140	80	140	130.5	12	393	448	M25x1.5	6207 ZZ	6206 ZZ
132S	216	45	248	272	218	140	N/A	187	89	150	132	16	75	266	319	132	159	80	140	130.5	12	452	519	M25x1.5	6308 ZZ	6207 ZZ
132M	216	51	248	271	218	178	55	225	89	150	132	20	75	266	319	132	178	79	140	133	12	490	557	2xM32x1.5	6308 ZZ	6207 ZZ

Shaft dimensions

Drive End (D.E.)

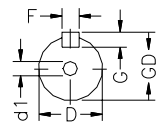

Non Drive End (N.D.E.)

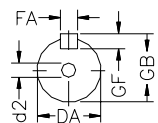

IEC Frame	Shaft Dimensions (mm)													
	D.E. shaft dimensions							N.D.E. shaft dimensions						
	ϕD	E	ES	F	G	GD	d1	ϕDA	EA	TS	FA	GB	GF	d2
63	11j6	23	14	4	8.5	4	EM4	9j6	20	12	3	7.2	3	EM3
71	14j6	30	18	5	11	5	DM5	11j6	23	14	4	8.5	4	EM4
80	19j6	40	28	6	15.5	6	DM6	14j6	30	18	5	11	5	DM4
90	24j6	50	36	8	20	7	DM8	16j6	40	28	5	13	5	DM6
100	28j6	60	45	8	24	7	DM10	22j6	50	36	6	18.5	6	DM8
112	28j6	60	45	8	24	7	DM10	24j6	50	36	8	20	7	DM8
132	38k6	80	63	10	33	8	DM12	28j6	60	45	8	24	7	DM10

16. W22 Mechanical data - frames 160 to 200

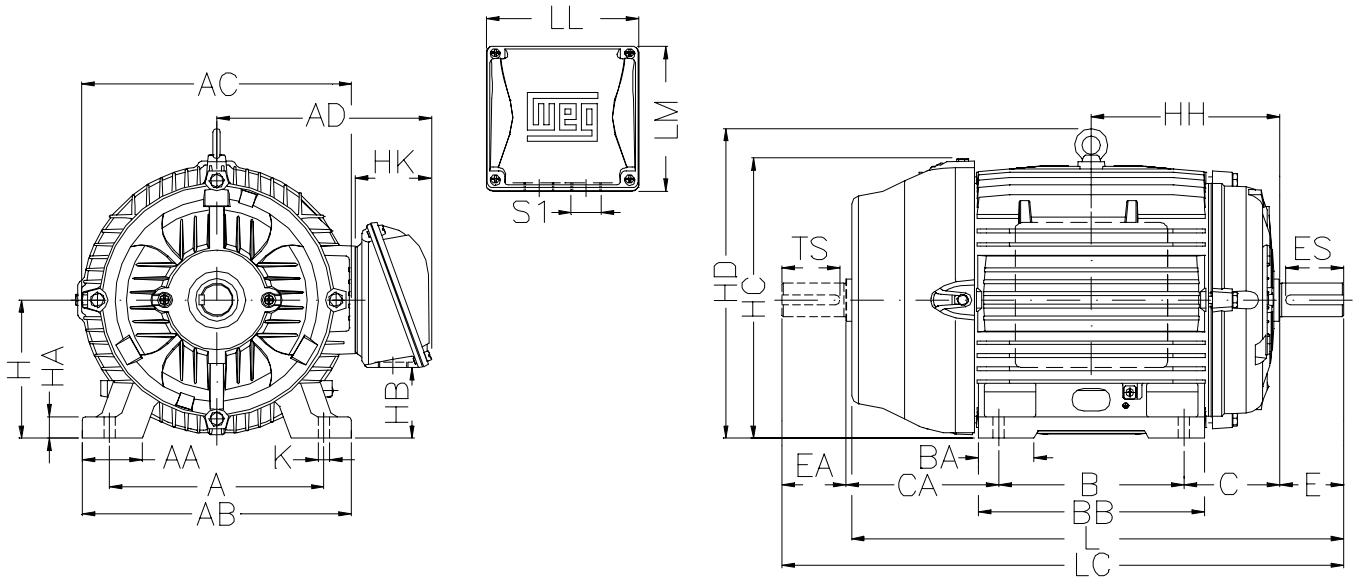

Main Dimensions (mm)																							Bearings			
IEC Frame	A	AA	AB	AC	AD	B	BA	BB	C	CA	H	HA	HB	HC	HD	HF	HH	HK	LL	LM	K	L	LC	S1	D.E.	N.D.E.
160M	254	64	308	329	264	210	63	254	108	174	160	22	79	327	374	168	213	100.5	198	188	14.5	598	712	2xM32x1.5	6309 C3	6209 Z-C3
160L	254	64	308	329	264	254	63	298	108	174	160	22	79	327	374	168	235	100.5	198	188	14.5	642	756	2xM32x1.5	6309 C3	6209 Z-C3
180M	279	78	350	360	279	241	70	294	121	200	180	28	92	363	413	180	241.5	100.5	198	188	14.5	664	782	2xM40x1.5	6311 C3	6211 C3
180L	279	78	350	360	279	279	70	332	121	200	180	28	92	363	413	180	260.5	100.5	198	188	14.5	702	820	2xM40x1.5	6311 C3	6211 Z-C3
200L	318	82	385	402	317	305	82	370	133	222	200	30	119	405	464	218	285.5	118	228	217	18.5	767	880	2xM50x1.5	6312 C3	6212 Z-C3

Shaft dimensions

Drive End (D.E.)

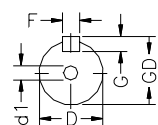

IEC Frame	Shaft Dimensions (mm)													
	D.E. shaft dimensions							N.D.E. shaft dimensions						
	Ø D	E	ES	F	G	GD	d1	Ø DA	EA	TS	FA	GB	GF	d2
160	42k6	110	80	12	37	8	DM16	42k6	110	80	12	37	8	DM16
180	48k6	110	80	14	42.5	9	DM16	48k6	110	80	14	42.5	9	DM16
200	55m6	110	80	16	49	10	DM20	48k6	110	80	14	42.5	9	DM20

Non Drive End (N.D.E.)

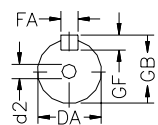

16. W22 Mechanical data - frames 225 to 355

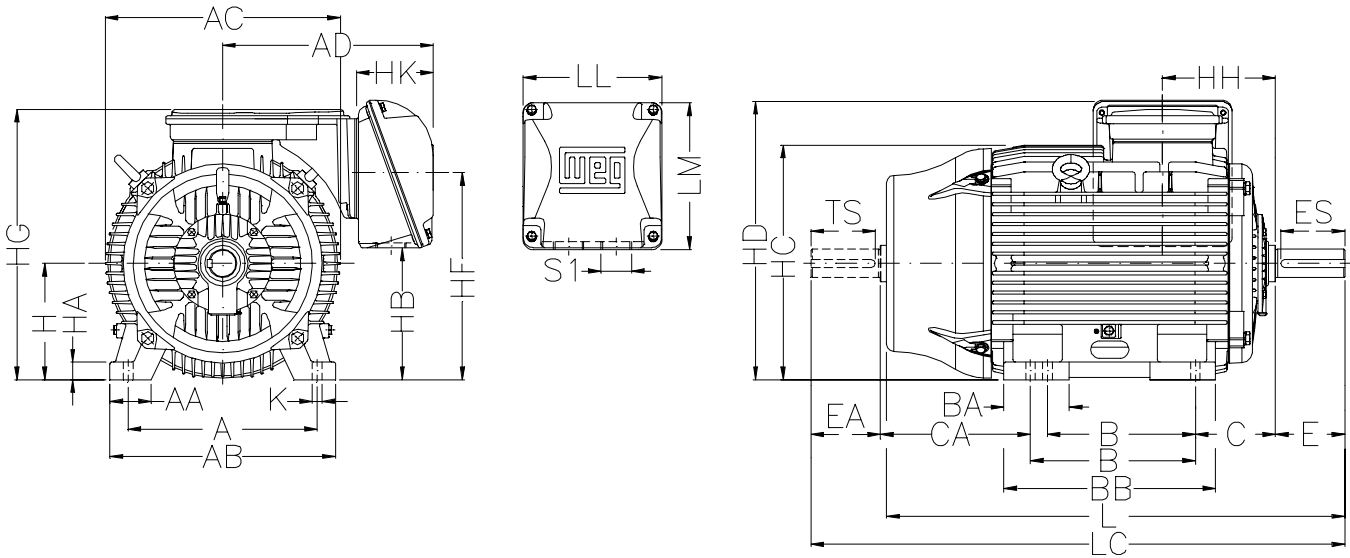

IEC Frame	Main Dimensions (mm)																									Bearings	
	A	AA	AB	AC	AD	B	BA	BB	C	CA	H	HA	HB	HC	HD	HF	HG	HH	HK	LL	LM	K	L	LC	S1	D.E. ¹	N.D.E.
225S/M 2P	356	80	436	455	408	286/311	124	412	149	319/294	225	34	255	453	550	403	523	212	153	269	285	18.5	856	974	2xM50x1.5	6314 C3	6314 C3
225S/M *	356	80	436	455	408	286/311	124	412	149	319/294	225	34	255	453	550	403	523	212	153	269	285	18.5	886	1004	2xM50x1.5	6314 C3	6314 C3
250S/M 2P	406	100	506	486	408	311/349	146	467	168	354/316	250	43	290	493	583	449	566	214	153	269	285	24	965	1113	2xM63x1.5	6314 C3	6314 C3
250S/M *	406	100	506	486	408	311/349	146	467	168	354/316	250	43	290	493	583	449	566	214	153	269	285	24	965	1113	2xM63x1.5	6316 C3	6314 C3
280S/M 2P	457	100	557	599	442	368/419	151	517	190	385/334	280	42	383	580	696	556	667	266	153	314	312	24	1071	1223	2xM63x1.5	6314 C3	6314 C3
280S/M *	457	100	557	599	442	368/419	151	517	190	385/334	280	42	383	580	696	556	667	266	153	314	312	24	1101	1253	2xM63x1.5	6319 C3	6316 C3
315S/M 2P	508	120	630	657	525	406/457	184	621	216	494/443	315	48	386	644	768	615	744	264	180	372	382	28	1244	1396	2xM63x1.5	6314 C3	6314 C3
315S/M *	508	120	630	657	525	406/457	184	621	216	494/443	315	48	386	644	768	615	744	264	180	372	382	28	1274	1426	2xM63x1.5	6319 C3	6316 C3
315L 2P	508	120	630	657	589	508	219	752	216	497	315	48	336	644	774	575	760	284	215	404	438	28	1353	1505	2xM63x1.5	6314 C3	6314 C3
315L *	508	120	630	657	525	406/457	184	621	216	494/443	315	48	386	644	768	615	744	264	180	372	382	28	1383	1535	2xM63x1.5	6319 C3	6316 C3
355M/L 2P	610	140	750	736	609	560/630	230	760	254	483/413	355	50	461	723	898	700	850	340	225	404	436	28	1412	1577	2xM80x2.0	6316 C3	6314 C3
355M/L *	610	140	750	736	609	560/630	230	760	254	483/413	355	50	461	723	898	700	850	340	225	404	436	28	1482	1647	2xM80x2.0	6322 C3	6319 C3

Shaft dimensions

Drive End (D.E.)

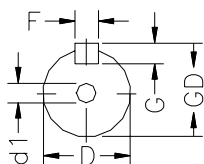

Non Drive End (N.D.E.)

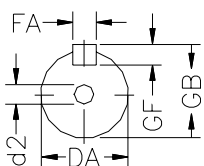

IEC Frame	Shaft Dimensions (mm)													
	D.E. shaft dimensions							N.D.E. shaft dimensions						
	Ø D	E	ES	F	G	GD	d1	Ø DA	EA	TS	FA	GB	GF	d2
225S/M 2P	55m6	110	100	16	49	10	DM20	55m6	110	100	16	49	10	DM20
225S/M *	60m6	140	125	18	53	11	DM20	60m6	140	125	18	53	11	DM20
250S/M 2P	60m6	140	125	18	53	11	DM20	60m6	140	125	18	53	11	DM20
250S/M *	70m6	140	125	20	62.5	12	DM20	60m6	140	125	18	53	11	DM20
280S/M 2P	65m6	140	125	18	58	11	DM20	60m6	140	125	18	53	11	DM20
280S/M *	80m6	170	160	22	71	14	DM20	65m6	140	125	18	58	11	DM20
315S/M 2P	65m6	140	125	18	58	11	DM20	60m6	140	125	18	53	11	DM20
315S/M *	85m6	170	160	22	76	14	DM20	65m6	140	125	18	58	11	DM20
315L 2P	65m6	140	125	18	58	11	DM20	60m6	140	125	18	53	11	DM20
315L *	85m6	170	160	22	76	14	DM20	65m6	140	125	18	58	11	DM20
355M/L 2P	75m6	140	125	20	67.5	12	DM20	60m6	140	125	18	53	11	DM20
355M/L *	100m6	210	200	28	90	16	DM24	80m6	170	160	22	71	14	DM20

Notes applicable to pages 28, 29 & 30:

1. W22 mining motors frames 225 to 355 4, 6 and 8 pole have NU roller bearings on D.E.

(*) Dimensions are applicable to 4, 6 and 8 pole motors.

16. W22 Flange dimensions

FF Flange (IEC) - frames 63 to 132

Mounting configurations B35, B5, V1, V3, V15, V36

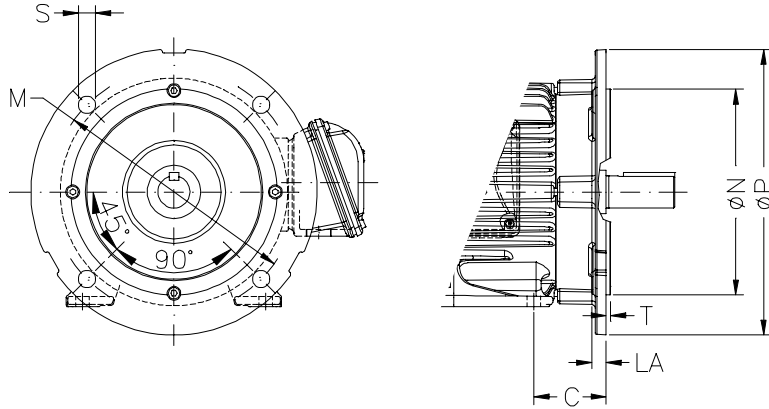

FF Flange (IEC)

IEC Frame	"FF" flange dimensions (mm)							No. of holes
	Flange	C	ØM	ØN	ØP	S	T	
63	FF-115	40	115	95	140	10	3	4
71	FF-130	45	130	110	160	10	3.5	4
80	FF-165	50	165	130	200	12	3.5	4
90	FF-165	56	165	130	200	12	3.5	4
100	FF-215	63	215	180	250	15	4	4
112	FF-215	70	215	180	250	15	4	4
132	FF-265	89	265	230	300	15	4	4

FF Flange (IEC) - frames 160 to 200

Mounting configurations B35, B5, V1, V3, V15, V36

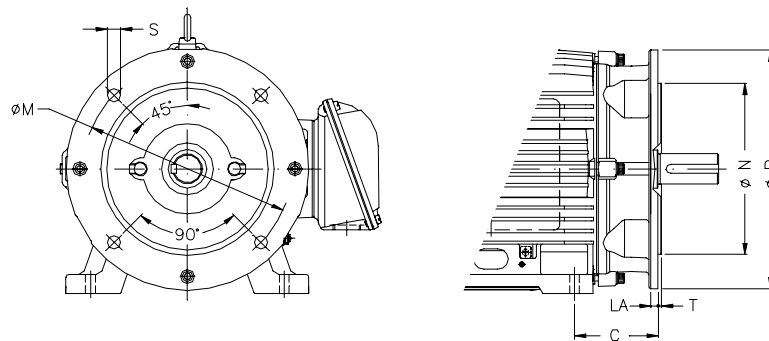

FF Flange (IEC)

IEC Frame	"FF" flange dimensions (mm)							No. of holes
	Flange	C	ØM	ØN	ØP	S	T	
160	FF-300	108	300	250	350	19	5	4
180	FF-300	121	300	250	350	19	5	4
200	FF-350	133	350	300	400	19	5	4

FF Flange (IEC) - frames 225 to 355

Mounting configurations B35, B5, V1, V3, V15, V36

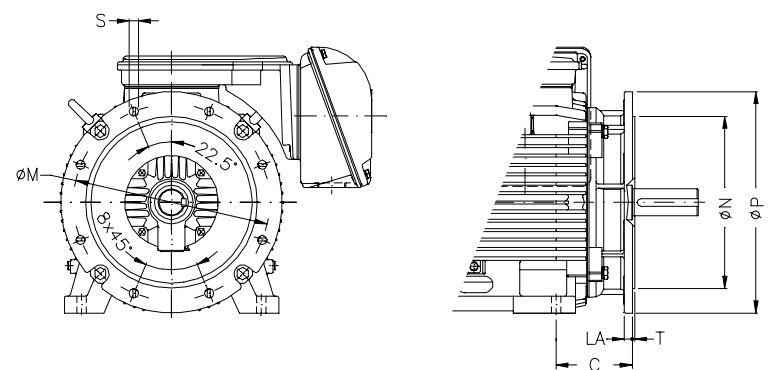

FF Flange (IEC)

IEC Frame	"FF" flange dimensions (mm)							No. of holes
	Flange	C	ØM	ØN	ØP	S	T	
225	FF-400	149	400	350	450	19	5	8
250	FF-500	168	500	450	550	19	5	8
280	FF-500	190	500	450	550	19	5	8
315	FF-600	216	600	550	660	24	6	8
355	FF-740	254	740	680	800	24	6	8



16. W22 Flange dimensions

C-DIN Flange (DIN 42677) (B14A) - frames 63 to 132

Mounting configurations B14, B34, V18, V19

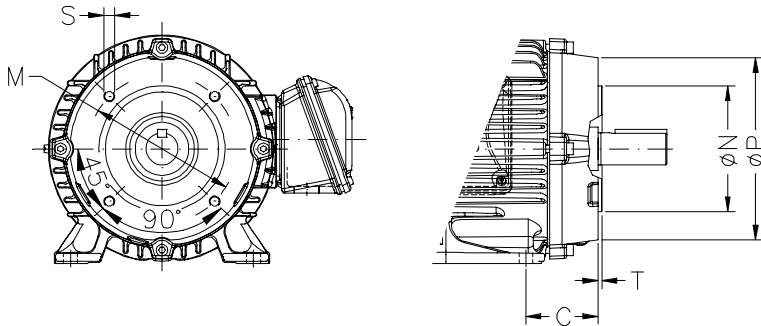

C-DIN Flange "Higher" (DIN 42677) (B14B) - frames 63 to 112

Mounting configurations B14, B34, V18, V19

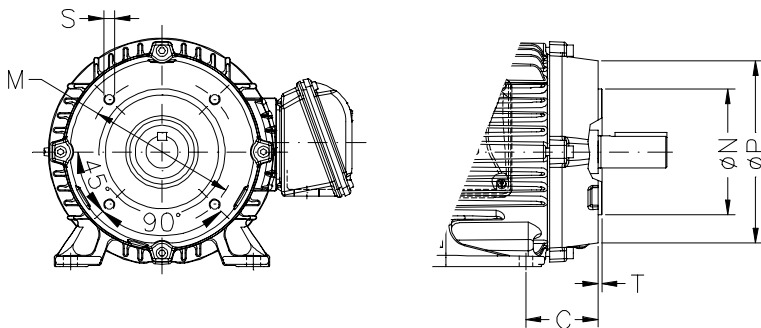

FC Flange (NEMA) - frames 63 to 132

Mounting configurations B14, B34, V18, V19

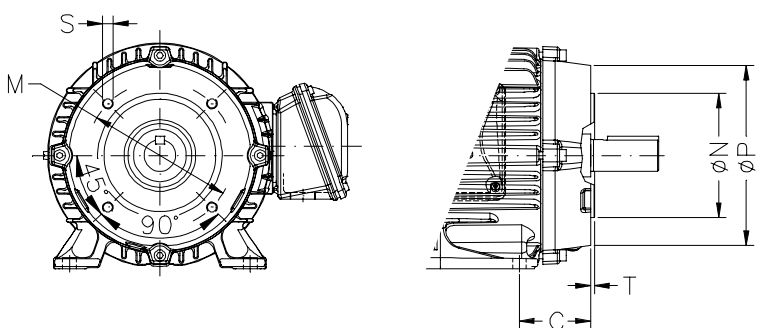

FC Flange (NEMA) - frames 160 to 200

Mounting configurations B14, B34, V18, V19

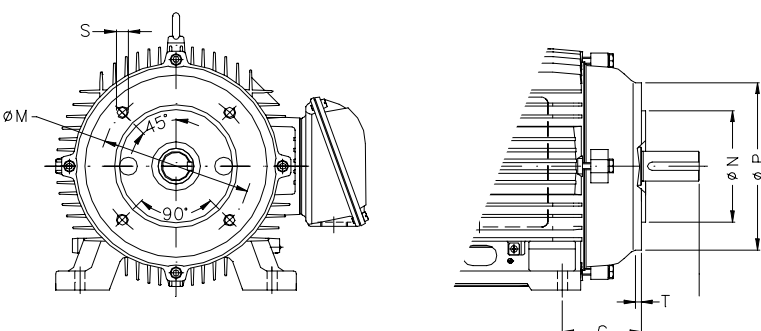

C-DIN Flange (DIN 42677) (B14A)

IEC Frame	"C" DIN flange dimensions (mm)							No. of holes
	Flange	C	ØM	ØN	ØP	S	T	
63	C-90	40	75	60	90	M5	2.5	4
71	C-105	45	85	70	105	M6	2.5	4
80	C-120	50	100	80	120	M6	3	4
90	C-140	56	115	95	140	M8	3	4
100	C-160	63	130	110	160	M8	3.5	4
112	C-160	70	130	110	160	M8	3.5	4
132	C-200	89	165	130	200	M10	3.5	4

C-DIN Flange "Higher" (DIN 42677) (B14B)

IEC Frame	"C" DIN flange dimensions (mm)							No. of holes
	Flange	C	ØM	ØN	ØP	S	T	
63	FG 063CD120GG	40	100	80	120	M6	3	4
71	FG 071CD140GG	45	115	95	140	M8	3	4
80	FG 080CD160GG	50	130	110	160	M8	3.5	4
90	FG 090CD160GG	56	130	110	160	M8	3.5	4
100	FG 100CD200GG	63	165	139	200	M10	3.5	4
112	FG 112CD200GG	70	165	130	200	M10	3.5	4

FC Flange (NEMA)

IEC Frame	"FC" flange dimensions (mm)							No. of holes
	Flange	C	ØM	ØN	ØP	S	T	
63	FC-95	40	95.2	76.2	143	UNC 1/4"x20	4	4
71	FC-95	45	95.2	76.2	143	UNC 1/4"x20	4	4
80	FC-95	50	95.2	76.2	143	UNC 1/4"x20	4	4
90	FC-149	56	149.2	114.3	165	UNC 3/8"x16	4	4
100	FC-149	63	149.2	114.3	165	UNC 3/8"x16	4	4
112	FC-184	70	184.2	151.9	225	UNC 1/2"x13	6.3	4
132	FC-184	89	184.2	151.9	225	UNC 1/2"x13	6.3	4

FC Flange (NEMA)

IEC Frame	"FC" flange dimensions (mm)							No. of holes
	Flange	C	ØM	ØN	ØP	S	T	
160	FC-184	108	184.2	151.9	225	UNC 1/2"x13	6.3	4
180	FC-228	121	228.6	266.7	280	UNC 1/2"x13	6.3	4
200	FC-228	133	228.6	266.7	280	UNC 1/2"x13	6.3	4

Notes applicable to pages 28, 29, 30, 31 & 32:

* For certified dimensions, please contact your nearest WEG office or business partner.

17. Terminal box drawings

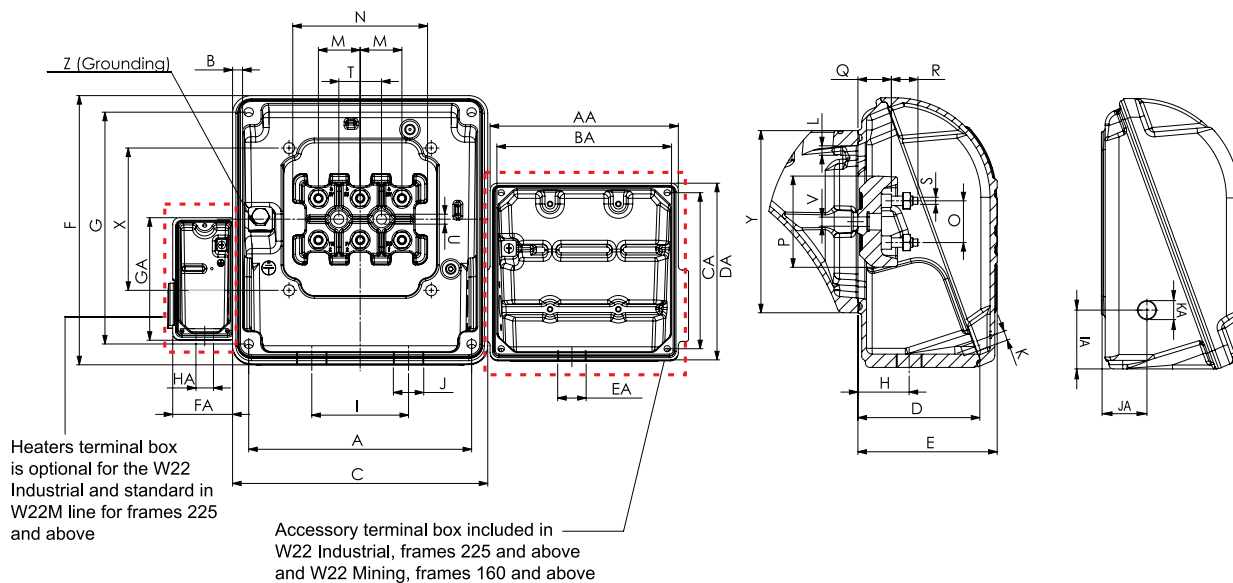

Frame	A	B	C	D	E	F	G	H	I	J	K	L	M	N	O	P	Q	R	S	T	U
63	90	8	108.5	50	59	96	85	27	42	M20x1.5	M5x0.8	M5x0.8	16	53	16	35	15.5	12	M4x0.7	20	5.8
71	90	8	108.5	50	59	96	85	27	42	M20x1.5	M5x0.8	M5x0.8	16	53	16	35	15.5	12	M4x0.7	20	5.8
80	90	8	108.5	50	59	96	85	27	42	M20x1.5	M5x0.8	M5x0.8	16	53	16	35	15.5	12	M4x0.7	20	5.8
90	98	7	114	58	67	101	91	31	42	M20x1.5	M5x0.8	M5x0.8	16	53	16	35	15.5	12	M4x0.7	20	5.8
100	98	7	114	58	67	101	91	31	42	M20x1.5	M5x0.8	M5x0.8	16	53	16	35	15.5	12	M4x0.7	20	5.8
112	117	7	138.5	69	80	130.5	117	36	54	M25x1.5	M6x1.0	M6x1.0	23	75	23	52	17	16	M5x0.8	23	6.5
132	117	7	138.5	69	80	130.5	117	36	54	M25x1.5	M6x1.0	M6x1.0	23	75	23	52	17	16	M5x0.8	23	6.5
160	175	8.5	198	86	100.5	188	175	46	84	2xM32x1.5	M8x1.25	M8x1.25	28	90	28	60	21.5	20.5	M6x1.0	28	6.6
180	175	8.5	198	86	100.5	188	175	46	84	2xM40x1.5	M8x1.25	M8x1.25	28	90	28	60	21.5	20.5	M6x1.0	28	6.6
200	204	9.5	228	101.5	118	216	204	56	94	2xM50x1.5	M8x1.25	M8x1.25	35	112	35	74	24	24	M8x1.25	35	9.5
225S/M	235	12.5	269	127	153	284	260	68	110	2xM50x1.5	M10x1.5	M10x1.5	44	140	44	94	32.5	28	M10x1.5	45	10.5
250S/M	235	12.5	269	127	153	284	260	68	110	2xM63x1.5	M10x1.5	M10x1.5	44	140	44	94	32.5	28	M10x1.5	45	10.5
280S/M	275	13.5	314	130	153	311	275	68	126	2xM63x1.5	M12x1.75	M12x1.75	45	153	45	108	35.5	40	M12x1.75	45	10.5
315S/M	340	14.5	379	156	180	380.5	345	82	160	2xM63x1.5	M12x1.75	M12x1.75	45	153	45	108	35.5	40	M12x1.75	45	10.5
315L	365	14.5	404	202	226	422	390	97	200	2xM63x1.5	M12x1.75	M14x2.0	65	210	65	146	48	48	M16x2.0	65	10.5
355M/L	365	14.5	404	195.5	225	424	390	97	200	2xM80x2.0	M12x1.75	M14x2.0	65	210	65	146	51	45	M16x2.0	65	10.5

Frame	V	X	Y	Z	Auxiliary Box					Heaters Box			IA	JA	KA	Max number of connectors		
					AA	BA	CA	DA	EA	FA	GA	HA				Main	Accessories	Space Heater
63	M5x0.8	56	77	0.5-6mm ²	108.5	90	85	96	M20x1.5	-	-	-	-	-	-	4	16	-
71	M5x0.8	56	78	0.5-6mm ²	108.5	90	85	96	M20x1.5	-	-	-	-	-	-	4	16	-
80	M5x0.8	56	81	0.5-6mm ²	108.5	90	85	96	M20x1.5	-	-	-	-	-	-	4	16	-
90	M5x0.8	56	77	0.5-6mm ²	108.5	90	85	96	M20x1.5	-	-	-	-	-	-	4	16	-
100	M5x0.8	56	81	0.5-6mm ²	108.5	90	85	96	M20x1.5	-	-	-	-	-	-	4	16	-
112	M5x0.8	70	107	2-10mm ²	108.5	90	85	96	M20x1.5	-	-	-	-	-	-	6	16	-
132	M5x0.8	70	107	2-10mm ²	108.5	90	85	96	M20x1.5	67.5	102	M20x1.5	-	-	-	6	16	4
160	M6x1.0	110	144	5.2-25mm ²	138.5	117	117	130	M20x1.5	67.5	102	M20x1.5	47	40	M20x1.5	12	26	4
180	M6x1.0	110	140	5.2-25mm ²	138.5	117	117	130	M20x1.5	67.5	102	M20x1.5	47	40	M20x1.5	12	26	4
200	M8x1.25	120	155	5.2-35mm ²	138.5	117	117	130	M20x1.5	67.5	102	M20x1.5	47	45	M20x1.5	12	26	4
225S/M	M10x1.5	150	192	25-50mm ²	198	175	175	187.5	M20x1.5	67.5	133	M20x1.5	62	48	M20x1.5	12	26	4
250S/M	M10x1.5	150	192	25-50mm ²	198	175	175	187.5	M20x1.5	67.5	133	M20x1.5	62	48	M20x1.5	16	26	4
280S/M	M10x1.5	150	207	35-70mm ²	198	175	175	187.5	M20x1.5	67.5	133	M20x1.5	77	56	M20x1.5	16	26	4
315S/M	M10x1.5	200	260	35-70mm ²	198	175	175	187.5	M20x1.5	67.5	133	M20x1.5	82	69	M20x1.5	16	26	4
315L	M10x1.5	260	300	85-120mm ²	198	175	175	189	M20x1.5	68.0	133	M20x1.5	97	79	M20x1.5	16	26	4
355M/L	M10x1.5	260	305	85-120mm ²	198	175	175	187.5	M20x1.5	67.5	133	M20x1.5	97	79	M20x1.5	16	26	4

18. Rainhood/Canopy

Utilisation of a rainhood/canopy increases the total length of the motor. The additional length can be seen on the table 31.



Figure 41 - Motor with rainhood/canopy

Frame	Dimension CH [increased motor length (mm)]
63	18
71	18
80	18
90	18
100	28
112	31
132	31
160	47
180	57
200	67
225S/M	81
250S/M	81
280S/M	91
315S/M	91
315L	91
355M/L	91

Table 31 - Rainhood dimension

19. Packaging

W22 motors in frames 63 to 132 are packaged in cardboard boxes (see figure 42), following are the dimensions, weights and volumes (refer table 32).



Figure 42 - Cardboard box

For frames 160 to 355A/B, the motors are packaged in wooden crates (see figure 43). Dimensions, weights and volumes (refer table 33).



Figure 43 - Wooden crates

Side mounted terminal box

Frame	External height (m)	External width (m)	External length (m)	Weight (kg)	Volume (m ³)
63	0.20	0.24	0.28	0.2	0.01
71	0.20	0.28	0.30	0.2	0.01
80	0.21	0.28	0.36	0.7	0.02
L80	0.24	0.32	0.40	0.8	0.03
90	0.24	0.32	0.40	0.8	0.03
100L	0.27	0.35	0.46	1.6	0.04
L100L	0.32	0.37	0.50	1.4	0.06
112M	0.31	0.38	0.46	1.7	0.05
132	0.35	0.48	0.60	2.1	0.10
160	0.50	0.40	0.74	9.2	0.15
180	0.53	0.43	0.82	12.3	0.19
200	0.59	0.51	0.88	13.5	0.27
225S/M	0.90	0.85	1.15	51.9	0.88
250S/M	0.90	0.85	1.25	54.6	0.96
280S/M	1.13	0.85	1.40	67.9	1.34
315S/M	1.13	0.85	1.55	69.9	1.49
315L	1.20	0.90	1.70	111	1.84
355M/L	1.32	1.05	1.73	127	2.40

Table 32 - Note: values to be added to the net motor weight

Top mounted terminal box

Frame	External height (m)	External width (m)	External length (m)	Weight (kg)	Volume (m ³)
63	0.26	0.21	0.30	0.2	0.02
71	0.26	0.21	0.30	0.2	0.02
80	0.27	0.26	0.36	0.7	0.02
90	0.32	0.27	0.43	0.9	0.04
100	0.33	0.27	0.46	1.4	0.04
112M	0.36	0.30	0.46	1.5	0.05
132	0.42	0.33	0.60	1.7	0.08
160	0.40	0.51	0.74	9.8	0.15
180	0.46	0.57	0.82	13.4	0.21
200	0.49	0.63	0.88	14.6	0.27
225S/M	0.78	0.85	1.15	47.7	0.76
250S/M	0.90	0.85	1.25	52.2	0.96
280S/M	0.95	0.95	1.40	71.6	1.26
315S/M	1.13	1.10	1.75	88.4	2.18
315L	1.10	1.12	1.70	138	2.10
355M/L	1.20	1.19	1.72	146	2.46

Table 33 - Note: values to be added to the net motor weight

W22 Industrial Motor

W22 Mining Motor

Based on state-of-the-art technologies which reduce carbon foot print from manufacturing, to installation and on-going use, the W22 range of E3 High Efficiency motors will reduce your operating, inventory and maintenance costs, whilst helping you achieve carbon emission targets.

With the quietest noise levels on the market, you will not find a simpler and more economical way to meet noise level regulations. High torques will keep your equipment running, even under severe load conditions.

When used with a VSD, our innovative WISE® insulation will deliver years of reliable operation. Combined with WEG's CFW11, the patented Optimal Flux® will provide savings never before experienced.

WEG welcomes you to a world of efficiency gains, reliable operation and carbon footprint reduction. This is our contribution to a sustainable future for generations to come.



20. Spare Parts

General Information

The following information is for reference only. The itemised codes are for identification purposes and are not spare parts ordering codes.

Spare Parts - frames 63 to 112

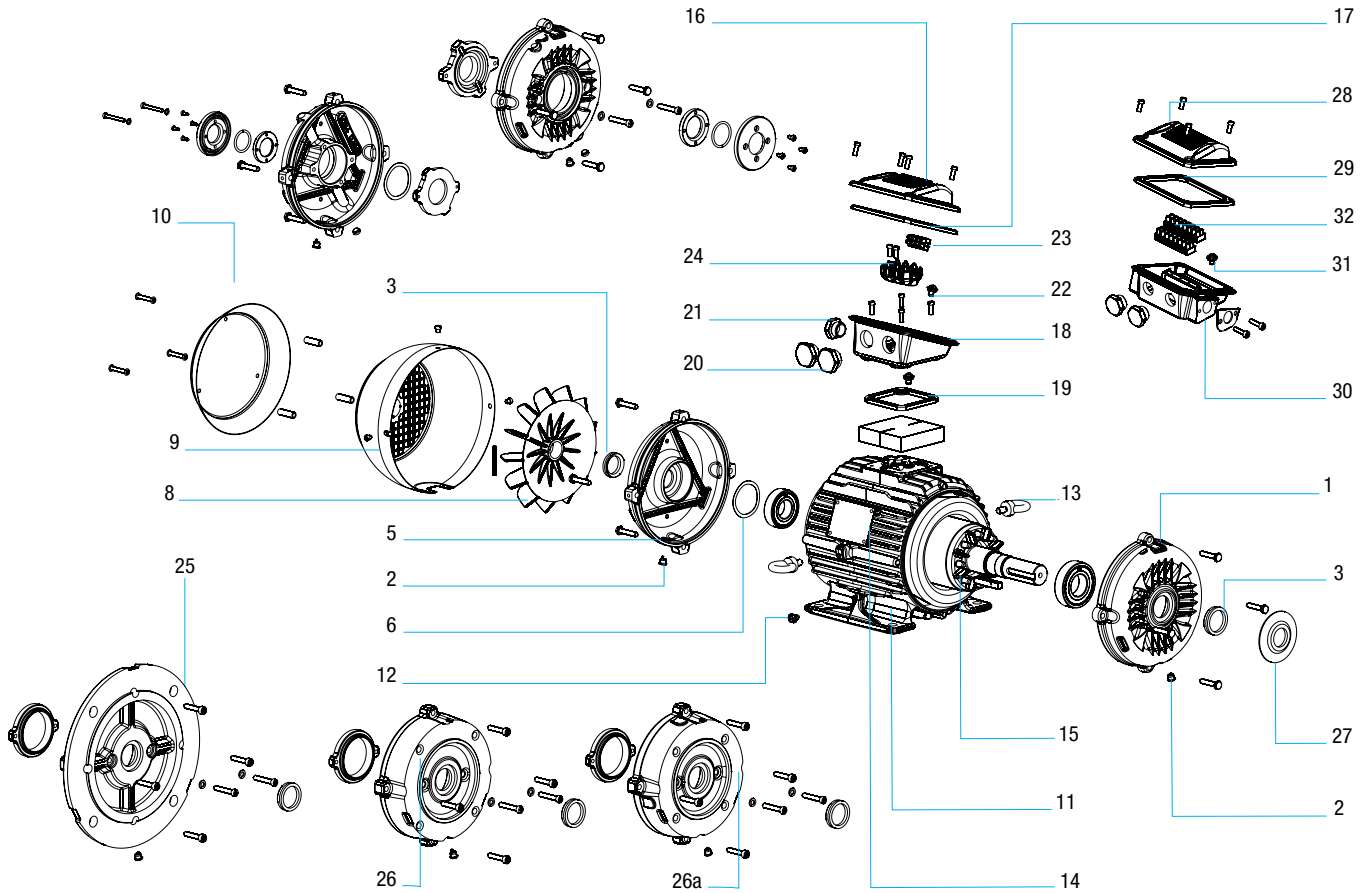

- | | |
|--|--|
| 1. Drive endshield | 20. Terminal box plug for main leads |
| 2. Drain plug | 21. Terminal box plug for accessory leads |
| 3. Shaft seal (2) | 22. Terminal box earthing terminal |
| 5. Non-drive endshield | 23. Accessory connector |
| 6. Wave washer for axial displacement | 24. Terminal block |
| 8. Fan (2) | 25. FF flange |
| 9. Fan cover (3) | 26. FC flange (4) |
| 10. Rainhood/canopy | 26a. C-DIN flange (4) |
| 11. Frame with wound stator | 27. Slinger |
| 12. Earthing terminal | 28. Accessory terminal box lid |
| 13. Lifting eyebolt | 29. Accessory terminal box lid gasket |
| 14. Main nameplate | 30. Accessory terminal box |
| 15. Rotor, complete with shaft and key | 31. Accessory terminal box earthing terminal |
| 16. Terminal box lid | 32. Accessory connector |
| 17. Terminal box lid gasket | |
| 18. Terminal box | |
| 19. Terminal box gasket | |

Notes:

- (1) The shaft seal may vary with product line. As a spare part, the shaft seal in the 63-112 range will be supplied as an integral part of the endshield kit
- (2) When non-plastic fan is fitted, the spare part kit includes key and circlip for fan assembly onto the shaft.
- (3) The fan cover material may vary with product line.
- (4) C flange dimensions are in accordance with either NEMA MG1 Part 4 (FC Flange) standard or DIN standards (C Flange).

20. Spare Parts

Spare Parts - frames 132 to 200

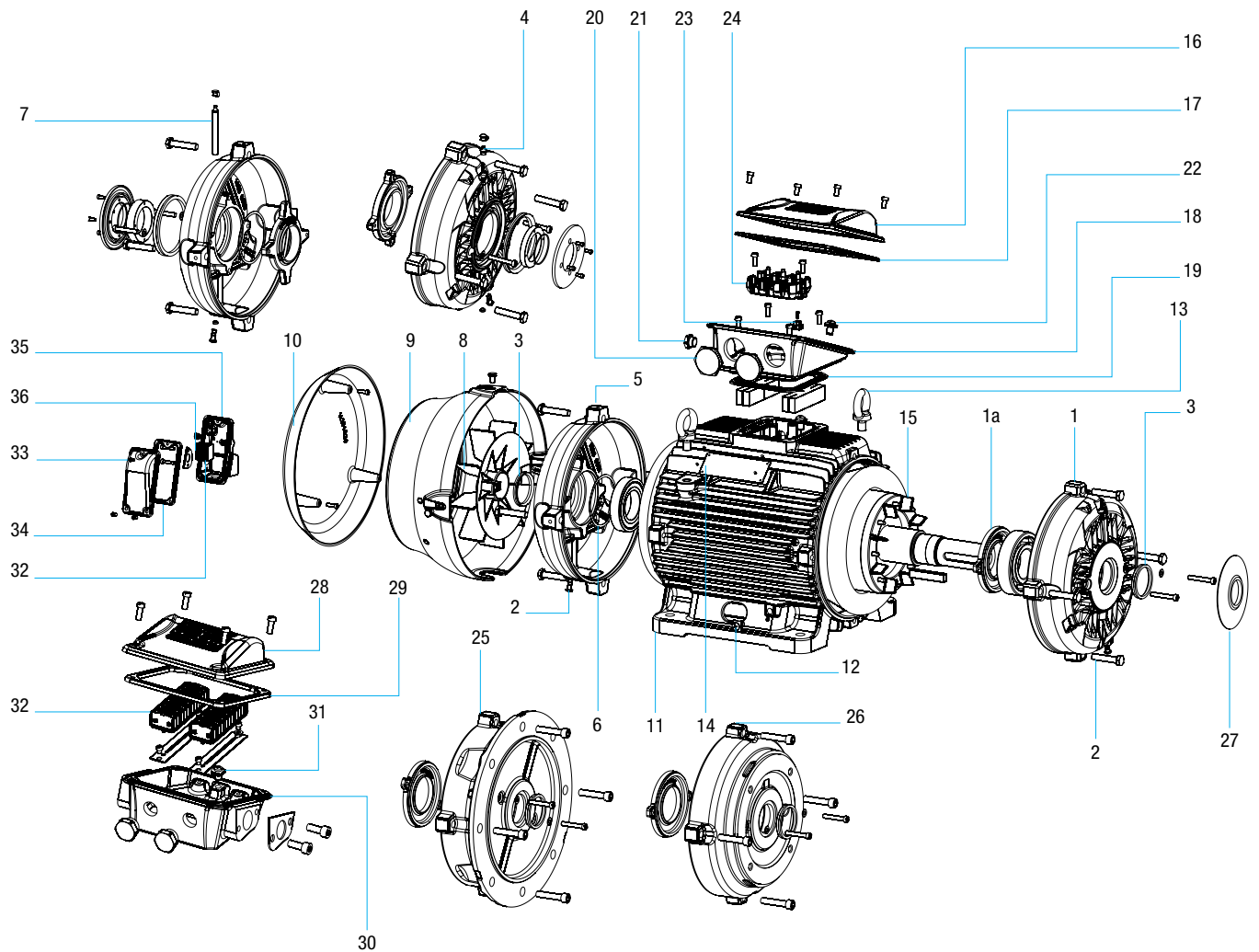

- | | |
|---|---|
| 1. Drive endshield | 19. Terminal box gasket |
| 1a. Bearing cap, internal | 20. Terminal box plug for main leads |
| 2. Drain plug | 21. Terminal box plug for accessory leads |
| 3. Shaft seal (1) | 22. Terminal box earthing terminal |
| 4. Grease nipple (2) | 23. Accessory connector |
| 5. Non-drive endshield | 24. Terminal block |
| 6. Wave washer for axial displacement | 25. FF flange |
| 7. Grease nipple with extensor pipe (2) | 26. C flange (5) |
| 8. Fan (3) | 27. Slinger |
| 9. Fan cover (4) | 28. Accessory terminal box lid |
| 10. Rainhood/canopy | 29. Accessory terminal box lid gasket |
| 11. Frame with wound stator | 30. Accessory terminal box |
| 12. Earthing terminal | 31. Accessory terminal box earthing terminal |
| 13. Lifting eyebolt | 32. Accessory connector |
| 14. Main nameplate | 33. Space heater accessory terminal box lid |
| 15. Rotor, complete with shaft and key | 34. Space heater accessory terminal box lid gasket |
| 16. Terminal box lid | 35. Space heater accessory terminal box |
| 17. Terminal box lid gasket | 36. Space heater accessory terminal box earthing terminal |
| 18. Terminal box | |

Notes:

- (1) The shaft seal may vary with product line. As a spare part, the shaft seal in frames 132-200 will be supplied as an integral part of the endshield kit.
- (2) When fitted with grease nipples, the endshield spare part kit will also have grease relief. Grease nipples are standard from 160 frame upwards.
- (3) When non-plastic fan is fitted, the spare part kit is also supplied with key and circlip for fan assembly onto the shaft.
- (4) The fan cover material may vary with product line.
- (5) C flange dimensions are in accordance with either NEMA MG1 Part 4 (FC Flange) standard or DIN standards (C Flange).

20. Spare Parts

Spare Parts - frames 225 to 355

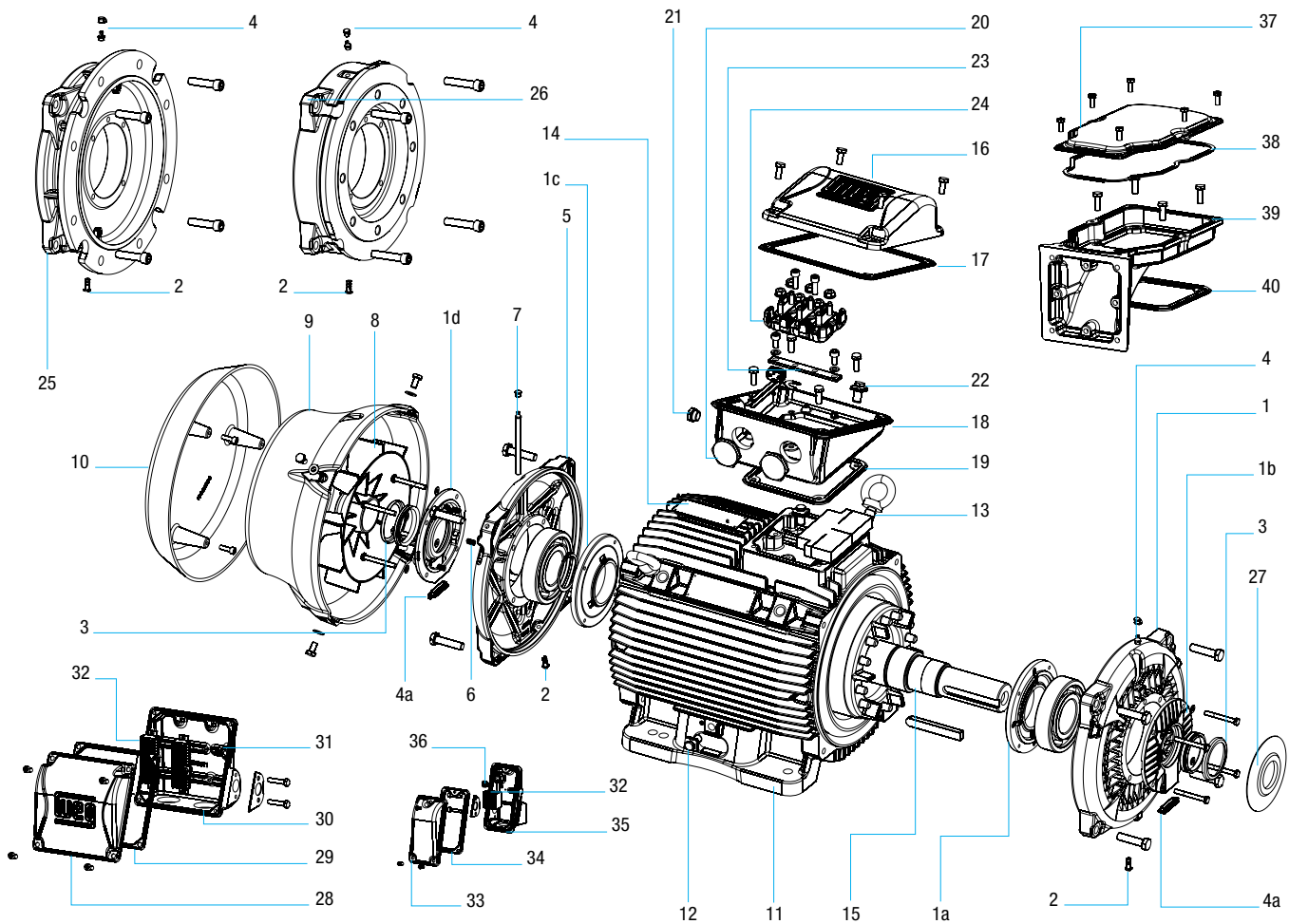

- | | |
|--|---|
| <ul style="list-style-type: none"> 1. Drive endshield 1a. Bearing cap, internal, drive end 1b. Bearing cap, external, drive end 1c. Bearing cap, internal, non-drive end 1d. Bearing cap, external, non-drive end 2. Drain plug 3. Shaft seal (1) 4. Grease nipple 4a. Grease relief 5. Non-drive endshield 6. Pre-loading springs 7. Grease nipple (with extensor pipe) 8. Fan (2) 9. Fan cover, cast iron 10. Rainhood/canopy 11. Frame with wound stator 12. Earthing terminal 13. Lifting eyebolt 14. Main nameplate (3) 15. Rotor, complete with shaft and key 16. Terminal box lid 17. Terminal box lid gasket | <ul style="list-style-type: none"> 18. Terminal box 19. Terminal box gasket 20. Terminal box plug for main leads 21. Terminal box plug for accessory leads 22. Terminal box earthing terminal 23. Accessory connector 24. Terminal block 25. FF flange 26. FC flange (4) 27. Slinger 28. Accessory terminal box lid 29. Accessory terminal box lid gasket 30. Accessory terminal box 31. Accessory terminal box earthing terminal 32. Accessory connector 33. Space heater accessory terminal box lid 34. Space heater accessory terminal box lid gasket 35. Space heater accessory terminal box 36. Space heater accessory terminal box earthing terminal 37. Terminal box adaptor lid 38. Terminal box adaptor lid gasket 39. Terminal box adaptor base 40. Terminal box adaptor base gasket |
|--|---|

Notes:

- (1) The shaft seal may vary with product line. As a spare part, the shaft seal in the 225-355 range will be supplied as an integral part of the bearing cap kit.
- (2) When non-plastic fan is fitted, the spare part kit is also supplied with key and circlip for fan assembly onto the shaft.
- (3) Main nameplate position will vary with terminal box configuration (top and side mounting).
- (4) FC flange dimensions according to NEMA MG1 Part 4 standard.

Start, Protect and Control with WEG.

VSD's, Relays and Starters



Motor Circuit Breakers

Solution for starting and protection of motors up to 55KW at 415V, with high interruption capacity



SRW01 Smart Relay

Current setting range from 0.5 to 840A. Suitable for various motor starting methods or in "Transparent" mode for motor monitoring, supervision and control



SSW06 Soft Starter

Available range 2.2 to 1950KW, 220 to 690V with Multi-motor start and motor protection features



AFW11 Modular Drive

Power range from 300 to 3000KW, 380 to 690V, available in kits for easy cubicle configuration and assembly

SSW7000 Soft Starter

Power range from 560 to 3350KW, 2.3kV, 4.16kV or 6.9kV, featuring Flexible Torque Control

CFW11 "IP54" Variable Frequency Drive

0.75 to 110KW, 380-480V with Internal PLC functionality (soft PLC) and Optimal Flux

CFW11 "IP20" Variable Frequency Drive

0.75 to 550KW, 380-480V with Internal PLC functionality (soft PLC) and Optimal Flux



CFW08 "Wash Duty" "IP56" Variable Frequency Drive

0.75 to 15KW, 220-240V and 380-480V with IP56 protection rating



WEG Australia

ADELAIDE

5/348 Richmond Road
Netley SA 5037
Phone: 08 8351 9822
Fax: 08 8351 9463

BRISBANE

100 Northlink Place
Virginia QLD 4014
Phone: 07 3265 9800
Fax: 07 3265 9888
qldsales@weg.com.au

MELBOURNE

14 Lakeview Drive
Scoresby VIC 3179
Phone: 03 9765 4600
Fax: 03 9753 2088
vicsales@weg.com.au

PERTH

Wilson House, Level 3
31 Winton Road
Joondalup WA 6027
Phone: 08 9400 5700
Fax: 08 9300 9779
wasales@weg.com.au

SYDNEY

512 Victoria Street
Wetherill Park NSW 2164
Phone: 02 9616 3900
Fax: 02 9725 4002
nswsales@weg.com.au



WEG Worldwide

Founded in 1961 in the state of Santa Catarina, Brazil by Werner Ricardo Voigt, Eggon João da Silva and Geraldo Werninghaus, WEG has amassed great experience in research/development, design, manufacture, testing and commissioning of motors, drives and transformers.

Our motor manufacturing capacity is one of the largest in the world, producing over 68,000 motors per day, equivalent to approximately 12 million per year. We employ over 25,000 people worldwide, with over 3,000 specialist engineers to support our customers from design, development, application, through to commissioning.

With factories, branches and technical services located around the world WEG offers complete solutions from small systems through to complex integrated projects. Offering over 20 state of the art testing laboratories, a large investment in research & development and a genuine focus on sustainability, WEG continually invests in the development of more efficient and environmentally friendly electrical solutions.

Testing and Technical Support

WEG has one of the world's largest testing facilities. We are able to perform full-load tests up to 20,000KW, ensuring accurate results at motor actual load conditions.

WEG tests 100% of its motors, drives and soft starters during production. These are quality control pass-or-fail tests, aimed at detecting any weakness in the materials or processes, hence ensuring the high quality of WEG products.

In addition, every control card on WEG drives and soft starters, undergo a full functional test, and the drive itself a two hour full load test.



AUSTRALIA

WEG AUSTRALIA PTY LTD
14 Lakeview Drive
Scoresby VIC 3179
Phone: 61 (3) 9765 4600
Fax: 61 (3) 9753 2088
www.weg.net/au

PROUDLY REPRESENTED AND SUPPORTED BY:

Distributore Ufficiale

FERRARI s.r.l.

26015 Soresina (CR) Italy

Via Cremona, 25

Tel. 0374 340404 Fax 0374 342413

www.ferrarisrl.it

ferrarisrl@ferrarisrl.it